



# Corrosion Testing Apparatus

Department of Mechanical and Mechatronic Engineering, Eastern Mediterranean University



## Introduction :

Corrosion is a characteristic and expensive procedure of destruction like earthquakes, tornados, floods, and volcanic ejections, with one significant contrast. While we can be just a quiet onlooker to the above procedures of annihilation, corrosion can be forestalled or possibly controlled. Corrosion is the aftereffect of cooperation between a metal and conditions which brings about its progressive decimation.

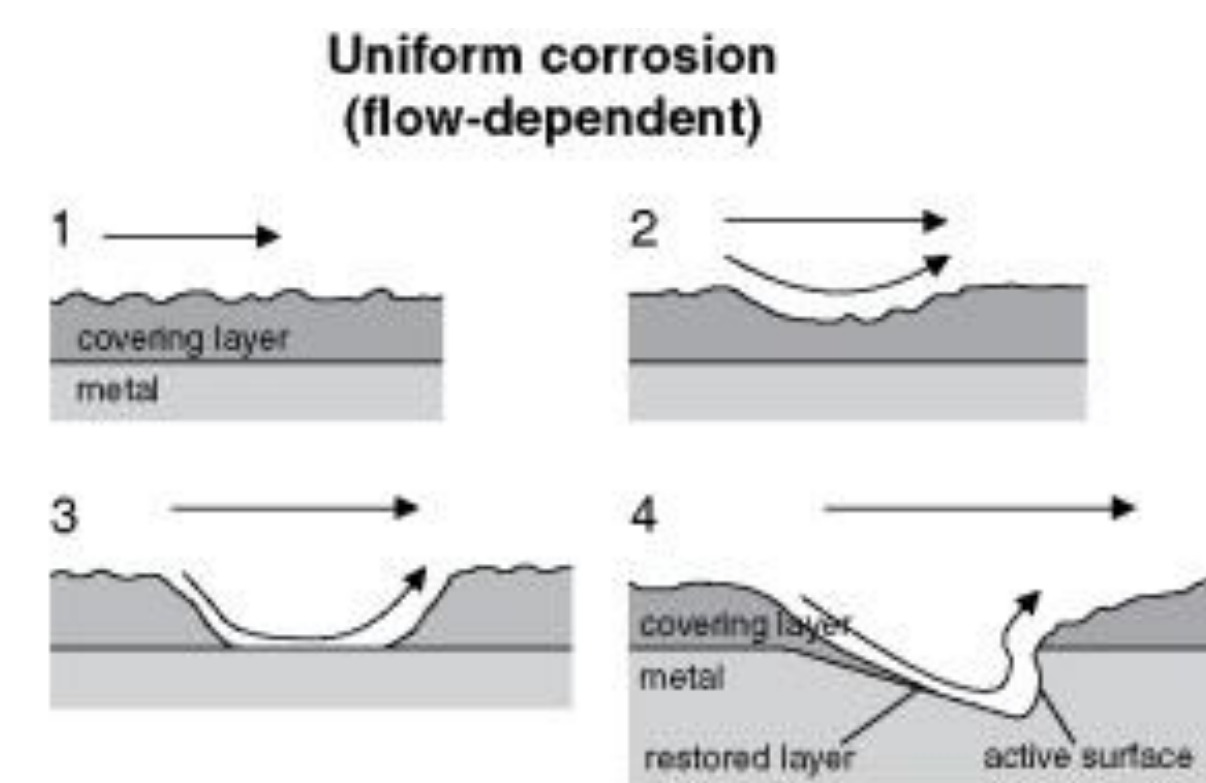

## Local corrosion

### 1. Caused by material inhomogeneities

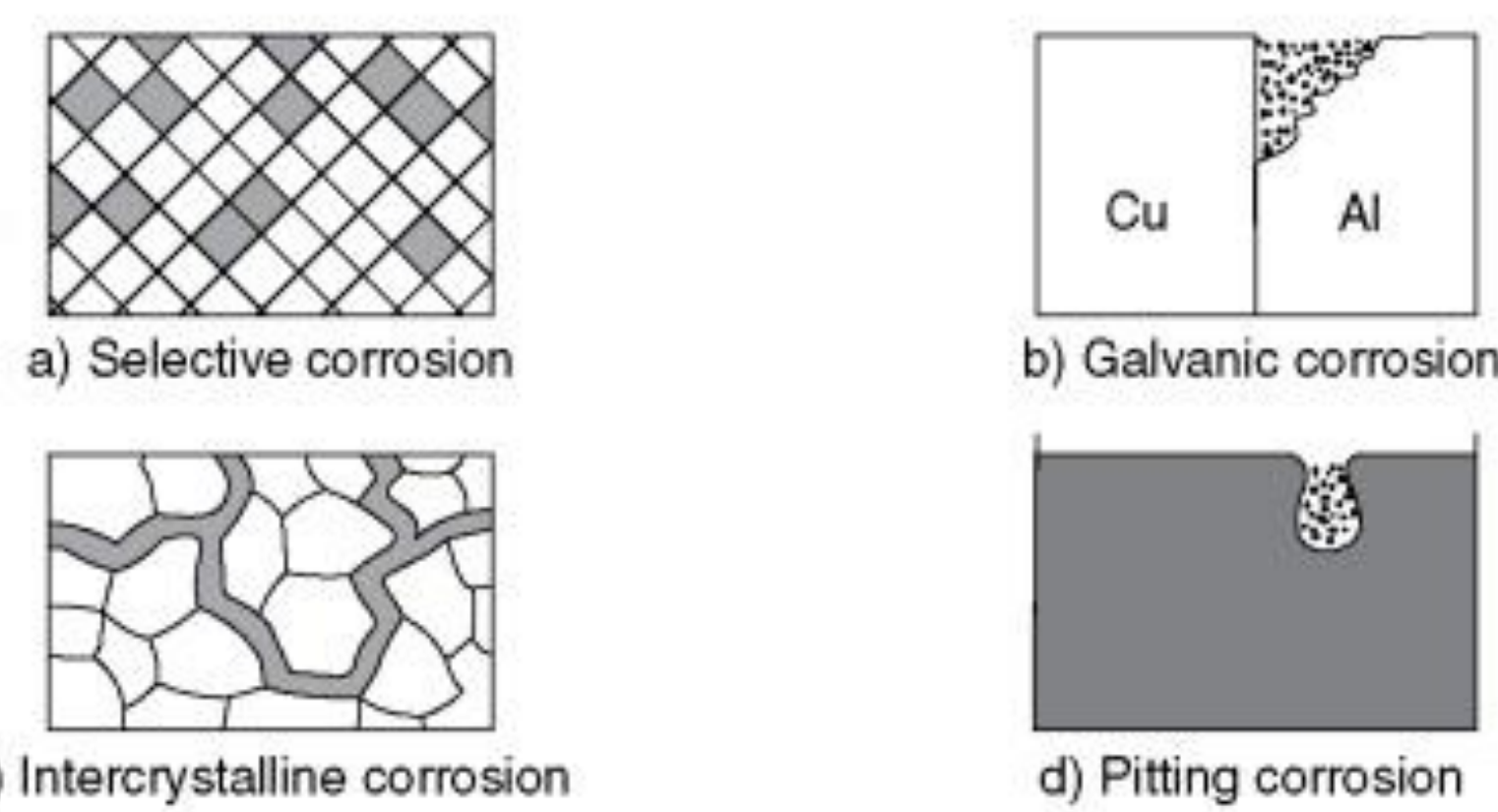

### 2. Caused by inhomogeneity at metal/liquid interface

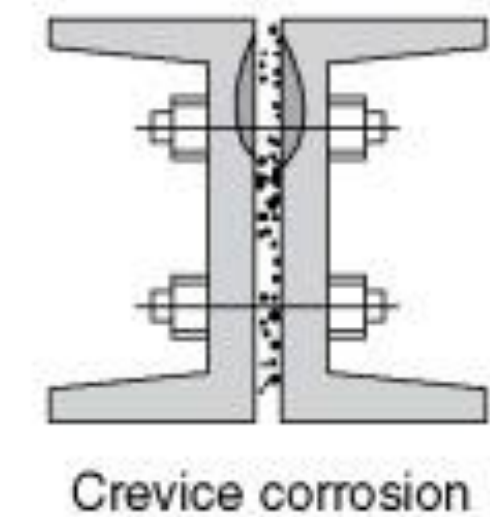

### 3. Caused by mechanical tensile stresses

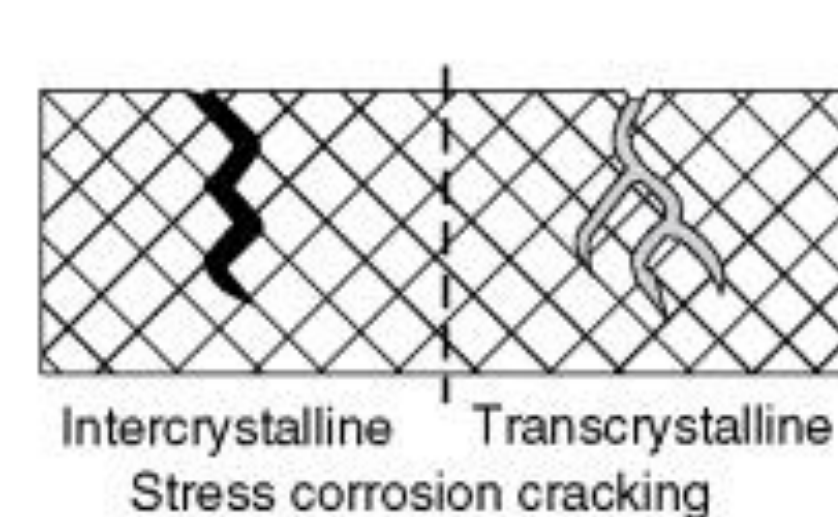

## Objective of the project:

The main objective of this project is the study and understand the behavior of corrosion on Aluminum and Steel and the effects in different environments, and how to treat corrosion and give the material better corrosion resistant properties.

## NSS, AASS and CASS:

The NSS test, offering neutral salt spray conditions with a pH ranging between pH 6.5 to 7.2 applies for metals and their alloys, most metallic coatings, anodic oxide coatings, organic coatings, and metallic materials. The AASS and CASS methods are much more corrosive than the ordinary salt spray method (NSS) and are very useful in enhancing electroplated parts is quality. Never the less the (NSS) method is much more common and more widely used in electroplating parts to be used in a seashore area, or close by the sea buildings, whilst it is cheaper which gives it an upper hand in comparison to AASS and CASS for a better comparison of these tests

## Machine design and execution:

The Machine was designed to allow for a uniform solution temperature in the testing chamber by using the water flow circulation system and a water heater which are both controlled manually.

## Design components:

- Base
- Container
- Titanium Heater
- DC Power Supply
- Water Pump

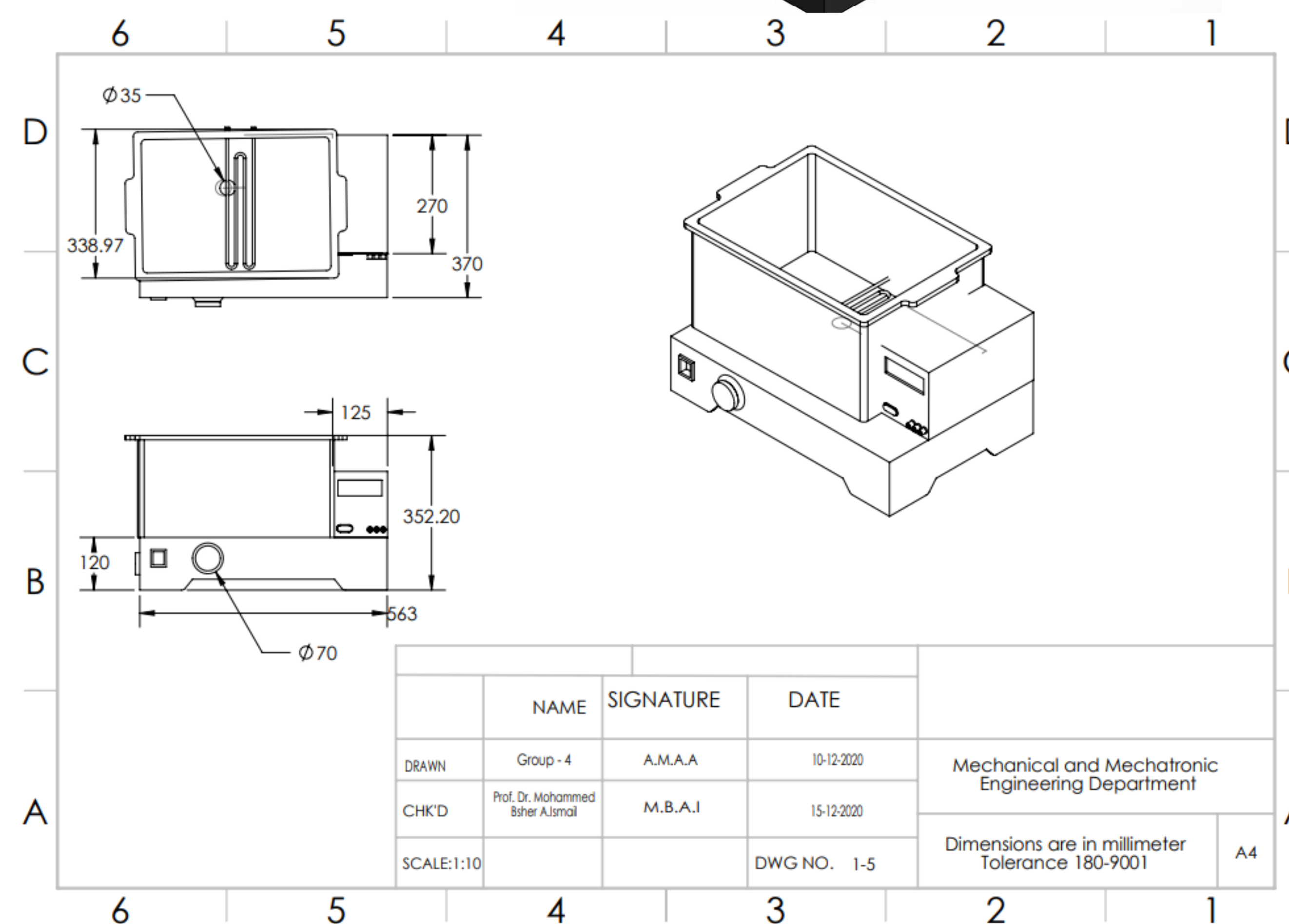
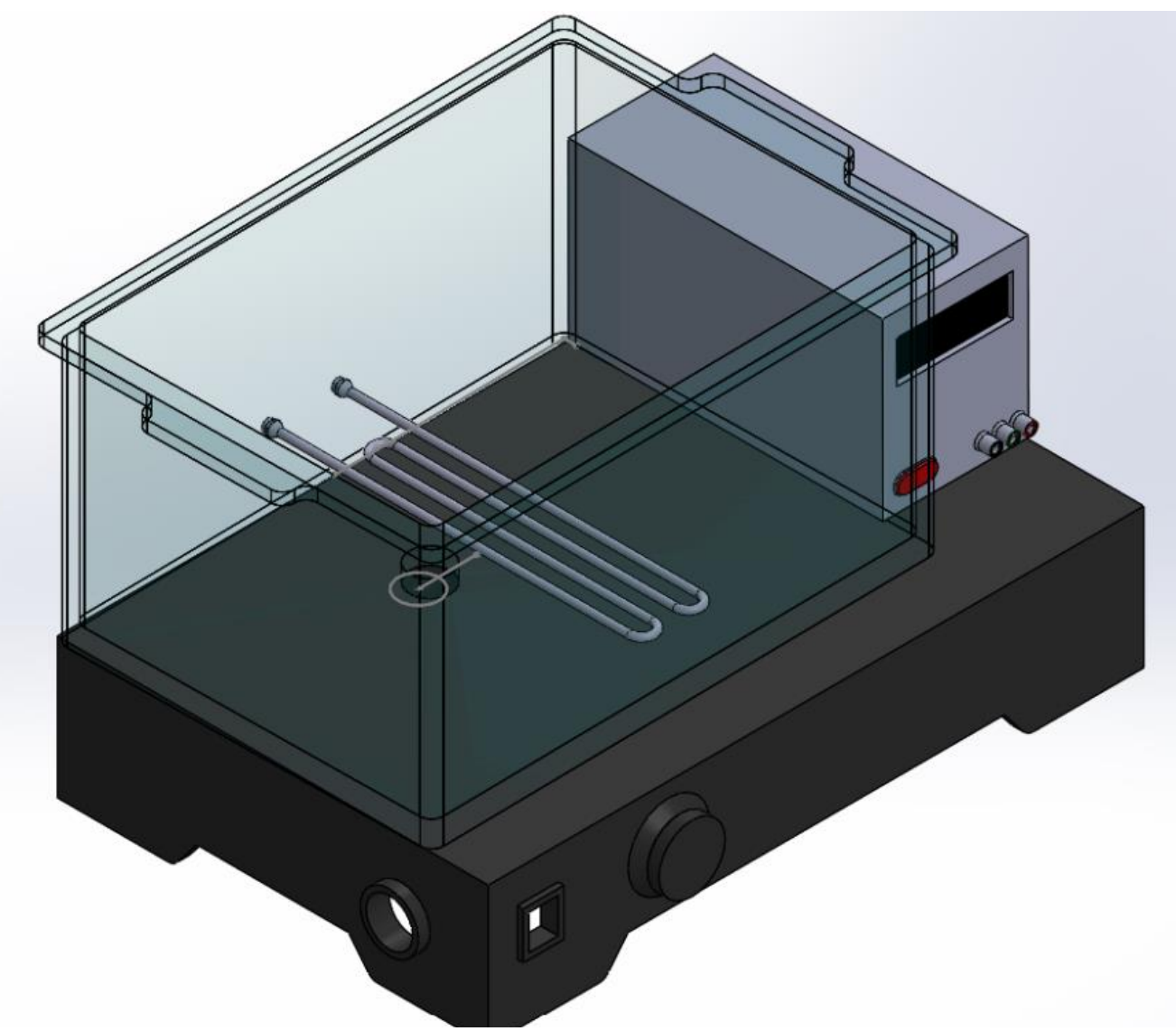

## Execution:

The base was designed to allow for all the parts to be on board with the ease of control for the test, with a hole on the top face to allow equipping a pump that connects the container and the drain pipe using thermal glue to close the gaps and eliminate any leakage, same technique was used to install the titanium heater, whilst connecting its ends to the control circuit to set to desired temperature, last but not least a light bulb was installed to the pump circuit to notify when it is running.

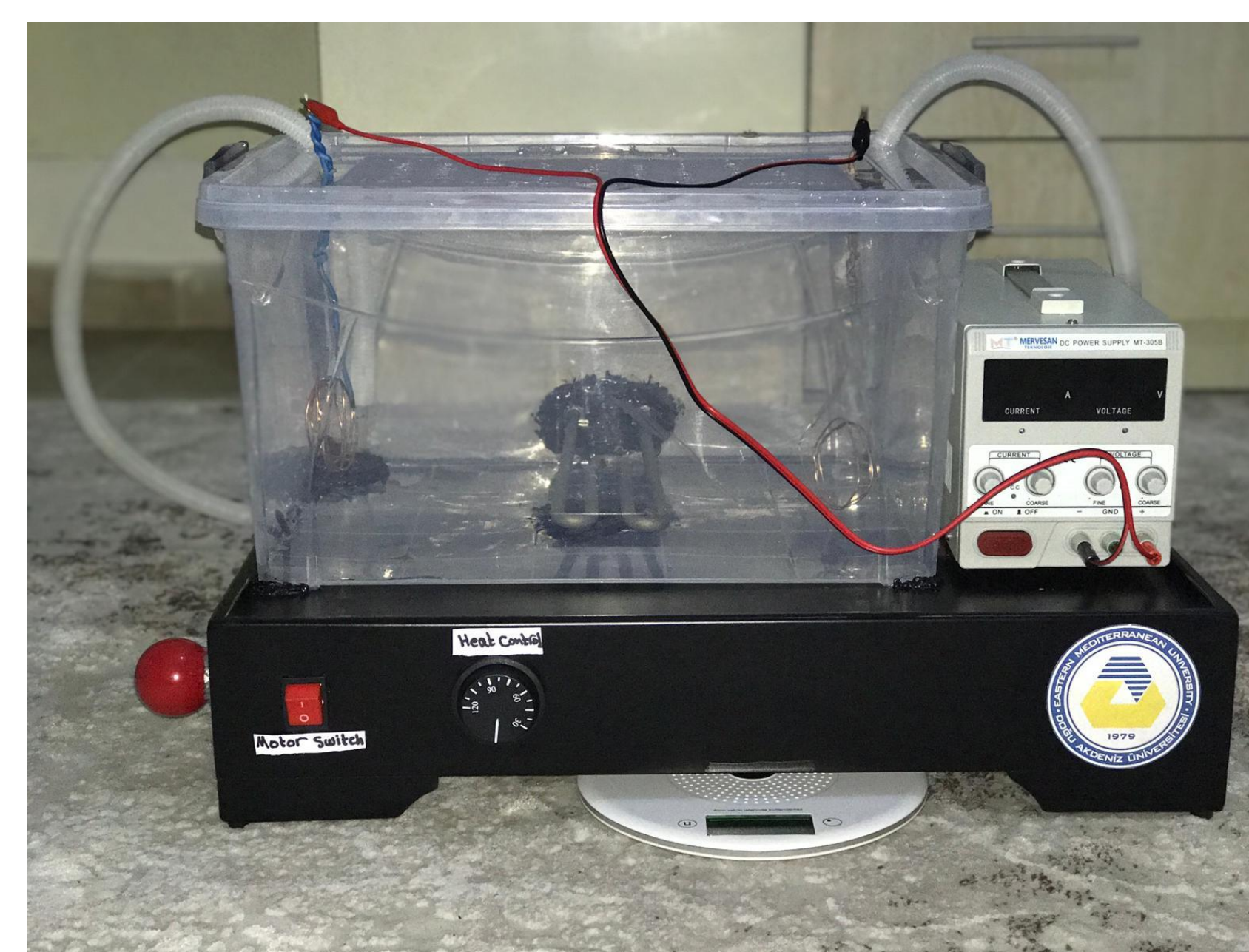

## Test results and obtained parameters:

The main result obtained by the tests is the corrosion rate, which is indicated as mm per year, this results helps estimate the lifetime of equipment under the same circumstances as the test, when given the thickness of the equipment or other related parameters.

All tests that were carried out, took around 90 min, each test was carried out at a different voltage and a different ampere., To describe how that affected the results here is a graph:

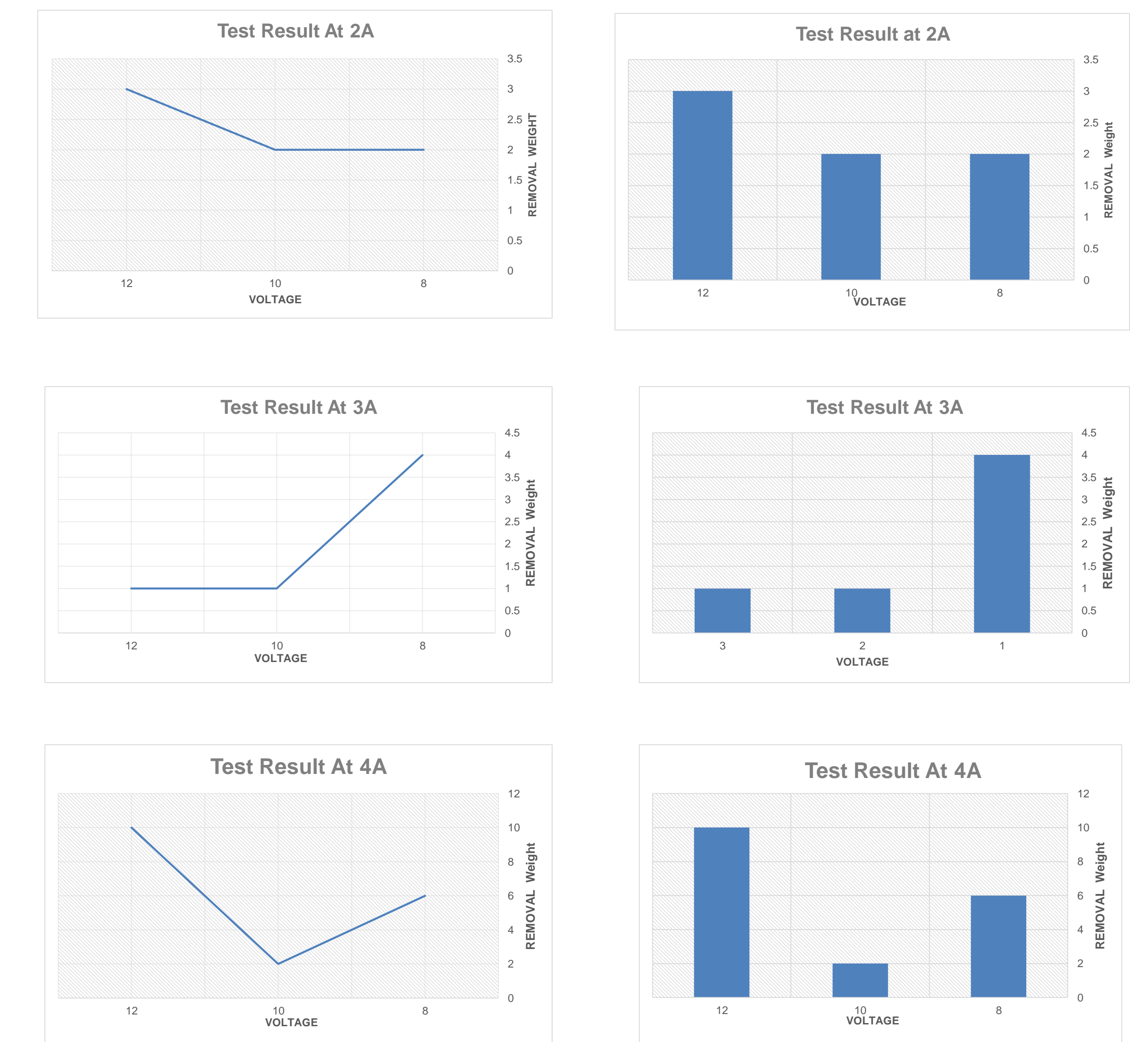

## Visual demonstration of the corrosion removal:

