

Capstone Team Project
MENG 411

Name of Project: *SNAKE ROBOT*

Group Name: *TEAM FER-DE-LANCE*

Group Members:

17701555 Shah Mohammed Isfar

17000072 Muratcan Yüce

16701509 Abdulrahman Saber Ali Mahfoodh

Supervisor: *Assoc. Prof. Dr. Qasim Zeeshan*

Semester: *Fall 2020/2021*

Submission Date: *9th January 2022*



Eastern Mediterranean University
Department of Mechanical Engineering

ABSTRACT

The following project describes the design, integration, reliability analysis, manufacturing plan and prototype testing plan of a low cost, orthogonally articulated snake robot. The snake robot will be programmed to scale various environments with the aid of servo motors integrated within each module via 3D printed PLA+ C-brackets. Navigational capabilities include sidewinding and other motion types controlled via Arduino Uno with an infrared remote-control system. The components and manufacturing processes have been selected with respect to reliability and structural analysis of mechanical and electronic parts, as well as cost, availability, environmental and safety factors.

In this project we aim to study a variety of snake robot concepts and prototypes that were previously developed with respect to modularity, redundancy, robustness, terrain-ability as well as cost, to implement specific characteristics and design methods to further refine our project to yield better performance. We also set a target to design a snake robot with relatively high manufacturability as well as improved battery capacity for longer run times with cost and availability in mind. The project also puts forward several constraints, the most significant ones being the availability and shipping of materials to the TRNC as well as the overall cost of the snake robot components, environmental factors, sustainability, ethical standards, health, and safety as well as manufacturing and assembly operations.

All the information and data used in this project has been compiled from the internet as well as various engineering manuals and textbooks and previously published research papers on snake robots.

TABLE OF CONTENTS

ABSTRACT.....	ii
LIST OF FIGURES.....	vi
LIST OF TABLES.....	viii
LIST OF SYMBOLS and ABBREVIATIONS.....	ix
CHAPTER 1 – INTRODUCTION.....	1
1.1. Detailed definition of the project.....	1
1.2. Significance of the project.....	1
1.3. Objectives of the project.....	2
1.4. Project constraints.....	3
1.5. Report organization.....	5
CHAPTER 2 - LITERATURE REVIEW.....	6
2.1. Background information.....	6
2.1.1. <i>Characteristics of snake robots</i>	11
2.2. Concurrent Solutions.....	17
2.2.1 <i>Bio-inspired Robotic Snake</i>	17
2.2.2. <i>Reconfigurable Robot Snake</i>	18
2.2.3. <i>Carnegie Mellon University Snake Robot</i>	19
2.2.4. <i>DIY Smart Snake Robot</i>	20
2.3. Comparisons of the Concurrent Solutions.....	21
2.4. Engineering standards of the concurrent solutions.....	26
CHAPTER 3 - DESIGN AND ANALYSIS.....	27
3.1. Proposed/Selected Design.....	27
3.1.1. <i>Joints</i>	29
3.1.2. <i>Servo motor</i>	31
3.1.3. <i>Electronic Components</i>	33
3.1.4. <i>Wi-Fi Camera</i>	35

3.1.5. <i>Remote Controller</i>	36
3.2. Engineering Standards	39
3.3. Design Calculations	40
3.3.1. <i>Servo Motor Calculations</i>	40
3.3.2. <i>Mass and Volume Calculations</i>	42
3.3.3. <i>Center of gravity</i>	45
3.4. Cost Analysis	47
3.5. Reliability analysis	52
3.5.1. <i>System Hierarchy</i>	52
3.5.2. <i>Product life cycle of the snake robot</i>	53
3.5.3. <i>Quality Function Deployment (QFD)</i>	55
3.5.4. <i>Failure data of snake robot components</i>	56
3.5.4.1. Sources for failure dataset A	56
3.5.4.2. Sources for failure dataset B	57
3.5.4.3. Sources for failure dataset C	59
3.5.5. <i>Reliability block diagrams of snake robot system and subsystem</i>	61
3.5.6. <i>Fault Tree Analysis (FTA)</i>	66
3.5.7. <i>Hazard and operability study (HAZOP)</i>	68
3.5.8. <i>System Design FMEA (Failure Modes and Effects Analysis)</i>	69
3.5.9. <i>Design for reliability</i>	72
3.5.9.1. Design phase	72
3.5.9.2. Manufacturing phase	74
3.5.9.3. Testing phase	75
CHAPTER 4 - MANUFACTURING PROCESS	76
4.1. Manufacturing Process Selection	76
4.1.1. <i>3D printing process selection</i>	76
4.1.2. <i>Shell material selection</i>	79
4.2. Detailed Manufacturing Process	80

4.2.1. <i>Detailed Manufacturing Process of 3D Printing</i>	81
4.2.2. <i>Snake Robot Assembly and Locations of the Electronic Components</i>	86
CHAPTER 5 - PRODUCT TESTING PLAN	93
5.1. Verification plan of the objectives of the project	94
5.1.1. <i>Test of electronic components</i>	95
5.1.2. <i>Test of 3D printer</i>	99
5.2. Verification plan of the applied engineering standards	101
CHAPTER 6 – RESULTS AND DISCUSSION	102
CHAPTER 7 – FUTURE WORKS	104
REFERENCES	106
APPENDIX A: Electronic Media	110
APPENDIX B: Standards	111
APPENDIX C: Constraints	113
APPENDIX D: Project Plan	115
APPENDIX E: Engineering Drawings	119
APPENDIX F: Component specifications	128
APPENDIX G: Codes	139

LIST OF FIGURES

<i>Figure 1: Snake robot developed in Matsuno Lab, moving over a flange.....</i>	<i>7</i>
<i>Figure 2: Active Chord Mechanism 3.....</i>	<i>8</i>
<i>Figure 3: A module of the ReBiS snake robot with one joint orthogonal to the other.....</i>	<i>10</i>
<i>Figure 4: ChainFORM robot by MIT.....</i>	<i>12</i>
<i>Figure 5: Different configurations of the 3-DOF parallel mechanism snake joint.....</i>	<i>14</i>
<i>Figure 6: The arrangement of segments in the OmniTread OT-4.....</i>	<i>16</i>
<i>Figure 7: OmniTread OT-4 held by user for size comparison.....</i>	<i>16</i>
<i>Figure 8: 2D Axis Bio-inspired Robotic Snake.....</i>	<i>18</i>
<i>Figure 9: Reconfigurable Robot Snake.....</i>	<i>19</i>
<i>Figure 10: Snakebot clinging to a pipe.....</i>	<i>20</i>
<i>Figure 11: DIY Smart Snake Robot.....</i>	<i>21</i>
<i>Figure 12: 3D rendering of snake robot prototype.....</i>	<i>27</i>
<i>Figure 13: Mechanical architecture of the snake robot.....</i>	<i>28</i>
<i>Figure 14: 2D servo mount design.....</i>	<i>30</i>
<i>Figure 15: Nose servo mount design.....</i>	<i>30</i>
<i>Figure 16: Tail servo mount design.....</i>	<i>30</i>
<i>Figure 17: Dimensions of the MG-996R.....</i>	<i>31</i>
<i>Figure 18: Arduino UNO board and names of each part on the board.....</i>	<i>33</i>
<i>Figure 19: KXN-3020D Adjustable Power Supply.....</i>	<i>34</i>
<i>Figure 20: OV767 type Wi-Fi Camera module.....</i>	<i>35</i>
<i>Figure 21: IR Remote Controller.....</i>	<i>36</i>
<i>Figure 22: Electronic architecture of the snake robot. S1 to S12 represent the servo motors</i>	<i>37</i>
<i>Figure 23: Program flowchart.....</i>	<i>38</i>
<i>Figure 24: n-link snake robot.....</i>	<i>45</i>
<i>Figure 25: Free body diagram of n-link snake robot.....</i>	<i>46</i>
<i>Figure 26: Pie chart showing percentage of each component cost out of total component cost.....</i>	<i>51</i>
<i>Figure 27: Pie chart showing percentage tax, 3D printing, shipping and components cost with respect to total cost.....</i>	<i>51</i>
<i>Figure 28: Snake robot system hierarchy.....</i>	<i>52</i>
<i>Figure 29: A bath-tub curve.....</i>	<i>54</i>
<i>Figure 30: Life cycle of the snake robot.....</i>	<i>54</i>
<i>Figure 31: RBD of structural and electrical subsystem.....</i>	<i>61</i>

<i>Figure 32: RBD of expanded structural subsystem</i>	62
<i>Figure 33: RBD of expanded electrical subsystem</i>	63
<i>Figure 34: RBD of expanded actuation system within the electrical subsystem</i>	64
<i>Figure 35: Boundary diagram of snake robot assembly</i>	65
<i>Figure 36: Fault Tree Analysis of snake robot</i>	66
<i>Figure 37: P-diagram of snake robot</i>	67
<i>Figure 38: Creality CR 10.</i>	82
<i>Figure 39: Printer settings displaying the thickness of the layers and infill characteristics.</i> ..	84
<i>Figure 40: Printer settings displaying the material properties, speed of the printer and cooling</i>	85
<i>Figure 41 - 3D printed parts arranged in order of assembly</i>	86
<i>Figure 42: Locations of electronic components</i>	87
<i>Figure 43 - Ball bearings to be fitted.</i>	89
<i>Figure 44 - Servo horn.</i>	90
<i>Figure 45 - Servo segments fitted with ball bearings and screws.</i>	90
<i>Figure 46 - Fresh printed 3D segment and sprayed segment.</i>	91
<i>Figure 47: Servo Motor Test Circuit</i>	96
<i>Figure 48: Servo Motor Tester</i>	96
<i>Figure 49: Simple test circuit for IR controller in Tinkercad</i>	97
<i>Figure 50: Test circuit for Wi-Fi camera</i>	98
<i>Figure 51: Clearance values of Tolerance Gauge Test part</i>	100

LIST OF TABLES

<i>Table 1: Robots inspired from nature.....</i>	<i>6</i>
<i>Table 2: Gait parameters</i>	<i>10</i>
<i>Table 3: PUGH's Matrix for snake robot concept selection</i>	<i>23</i>
<i>Table 4: PUGH's Matrix for selecting axes of snake robot</i>	<i>24</i>
<i>Table 5: PUGH's Matrix for bracket selection.....</i>	<i>25</i>
<i>Table 6: PUGH's Matrix for servo motor selection.....</i>	<i>25</i>
<i>Table 7: Engineering Change Order for servo motors</i>	<i>32</i>
<i>Table 8: Servo Motor Specifications.....</i>	<i>40</i>
<i>Table 9: Physical properties of 3D printed parts calculated in SolidWorks.....</i>	<i>43</i>
<i>Table 10: 1 kg PLA+ Filament Properties.....</i>	<i>44</i>
<i>Table 11: Mass of all integrated components.....</i>	<i>44</i>
<i>Table 12: Bill of Materials.....</i>	<i>47</i>
<i>Table 13: Total cost prediction.....</i>	<i>50</i>
<i>Table 14: Failure dataset A</i>	<i>57</i>
<i>Table 15: Failure dataset B</i>	<i>59</i>
<i>Table 16: Failure dataset C</i>	<i>60</i>
<i>Table 17: Hazard and operability study of snake robot.....</i>	<i>68</i>
<i>Table 18: Snake robot system DFMEA</i>	<i>69</i>
<i>Table 19: Snake robot system DFMEA (continued)</i>	<i>70</i>
<i>Table 20: Severity occurrence and detection ratings</i>	<i>71</i>
<i>Table 21: 3D-Printer Types.</i>	<i>77</i>
<i>Table 22: Comparisons of the 3D Printer Type.....</i>	<i>78</i>
<i>Table 23: Mechanical properties of PLA and ABS.....</i>	<i>79</i>
<i>Table 24: Comparisons of the 3D Printer Filament type.....</i>	<i>80</i>
<i>Table 25: Number of parts in snake robot assembly and spare parts.</i>	<i>82</i>
<i>Table 26: Product parameters for the CR 10 3D printer.</i>	<i>83</i>
<i>Table 27: Properties of KXN-3020D Adjustable Power Supply</i>	<i>88</i>

LIST OF SYMBOLS and ABBREVIATIONS

m_i : Mass of link

n : Number of links

l_i : Length

J_i : Moment of inertia

(x_{ci}, y_{ci}) : Center of gravity coordinates

(x_b, y_b) : Coordinates of end of tail link

Θ_i : Angle between link and x-axis

d_i : Location of mass center of i^{th} link

T_i : Joint torque from the servo motors

T : Torque generated

I_R : Resultant current

V_o : Operation voltage

I_o : Operation current

f_{ni} and f_{ti} : Force due to the friction between the links and the horizontal surface

ϕ_i : Relative angles of two adjacent links

1D: One dimensional

2D: Two dimensional

3D: Three dimensional

ReBiS: Reconfigurable Bipedal Snake#

ACM: Active Chord Mechanism

NASA: National Aeronautics and Space Administration

MIT: Massachusetts Institute of Technology

PID: Proportional Integral Derivative

LiPo: Lithium Polymer

ISO: International Organization for standardization

ASTM: American Society for Testing and Materials

PLA: Printed Circuit Board

IC: Integrated Circuit

IR: Infrared

USB: Universal Serial Bus
CMOS: Complementary metal-oxide semiconductor
VGA: Video graphics Array
FPN: Fixed-Pattern Noise
LED: Liquid Emitting Diode
AC: Alternating current
DC: Direct current
SLA: Stereolithography
DLP: Digital Light Processing
FDM: Fused Deposition Modeling
SLS: Selective laser Sintering
SLM: Selective Laser Melting
EBM: Electron Beam Melting
LOM: Laminating Object Manufacturing
PLA: Polylactic acid
ABS: Acrylonitrile Butadiene Styrene

CHAPTER 1 – INTRODUCTION

1.1. Detailed definition of the project

The purpose of the snake robot in this project is to help the user in surveying confined environments. Such environments include sheltered work environments as well as unsheltered environments. The snake robot will operate with 12 Tower Pro MG996R servo motors in a parallel configuration connected via 3D printed custom C-brackets with one bracket fixed in an alternating orthogonal orientation relative to the previous bracket, an infrared remote-control system to move the robot in specific directions in the selected mode of motion, an external variable power supply connected to the tail segment of the snake and a governing Arduino Uno microcontroller board based on ATmega328P, to send signals. The head of the snake robot will be equipped with an off-the-shelf Arduino Camera module that will be used to monitor surrounding via WIFI. The diverse types of snake locomotion will be planned and coded to suite a given environment or terrain and modes of motion can be easily switched by the user via the infrared remote-control system. The aim is to first incorporate sidewinding motion, as it is the most used mode of motion in multi-linked servo systems using sine and cosine functions, to the snake robot and conduct the relevant mathematical planning with MATLAB and simulation programs before further exploring other modes of locomotion. In this project the team will expand on the design selections with respect to several concurrent solutions and ongoing projects encompassing bio-inspired robot design and elaborate the manufacturing processes, testing plan, marketing strategies and reliability analysis of the snake robot at a system and sub-system level.

1.2. Significance of the project

Snake robots have the potential to be a solution to some of the problems faced by people that live in natural disaster affected regions. The operational flexibility of a snake robot will

allow users to probe areas that cannot be easily accessible to humans. For example, after the collapse of a building, search and rescue operations must be conducted but without the aid of robots that are able to use sensors and devices to find trapped residents, the entire operation is mostly based on trial and error. This conventional form of search and rescue is not very efficient, as there may be human errors that can result in poor time management, eventually being the cause of death and injury due to prolonged exposure to a dangerous surrounding.

Snake robots can also be used in industrial settings to probe confined areas like pipes and machines where it is unsafe for technicians to directly inspect. It is less time consuming to diagnose faults using a camera module mounted on the head of the snake robot or even a different end affecter like a gripper arm or drill depending on the scenario. This means there are shorter downtimes for the system, as there is no need to dismantle certain major parts of the system to initiate a diagnosis.

1.3. Objectives of the project

The focus of this project is to integrate existing technologies, components, and method to design a snake robot that can be used to probe and collect data from various environments. This project will also be based on design for cost, where we will be introducing inexpensive, readily available components as well as reducing the overall dimensions to allow us to investigate and probe confined environments, therefore there will be compromises made in terms performance, weight as well as battery life. However, we aim to create a low-cost benchmark model that can be used in the future to study various snake robot gaits as well as provide engineers with a platform to work towards a more efficient modular design. To gain a good perspective on how this device will be developed, we will list the main objectives or goals set after careful study of earlier device designs. The prime objectives of the project are listed as follows.

- **Design for cost** – Utilize readily available and inexpensive materials and components in our snake robot. In this project we aim to minimize cost of components and sub-components without a significant reduction in product performance or deviation from other objectives of the project.
- **Design for manufacturability** - Devise a plan to manufacture the robot as well as provide a cost analysis of all mechanical, electrical and software components. The project team aims to create a snake robot that can be easily assembled without the need for expensive equipment, space, and assembly time. Components and sub-components must be planned in a way that they can be integrated without inducing a large manufacturing cost.
- **Design for reliability** - Analyze the system in terms of reliability of each component and provide an overview on how it can be improved in future developments.
- **Design for safety** – Design a technically and aesthetically safe product that will not cause harm to the user and protect the user from possible harm. This includes insulating electrical wiring and certain electronics as well as printing smooth shapes and edges for the shell structure of the snake robot.
- **Design for environment** – Minimize harmful by products, waste materials as well as energy usage expenditures in the design and manufacturing phase of the snake robot. Plan for more efficient energy consumption as well as the proper disposal of parts like batteries and 3D printed PLA+ shell.

1.4. Project constraints

In the project, during the various stages of design and testing, we will be faced with several project constraints. Below is a list of project constraints and a summary of each:

- **Economic** – Efficient use of the available budget for the project in terms of material and component choice. The various mechanical and electronic parts used in this project will

heavily depend on their availability as well as shipping from an external source to the TRNC and therefore will be selected accordingly. Availability will also affect the manufacturability of the product.

- **Sustainability** – A well-defined life span under the assumed normal operation conditions. Consideration of environmental factors in design. Reliability and durability of the products supposed function.
- **Manufacturability** – The manufacturing process will be decided with respect to the materials selected in the initial stages of the design as well as the availability of these materials. The economic factor mentioned earlier also coincides with manufacturability as we aim to utilize inexpensive manufacturing techniques and components without causing significant reduction in the overall performance of the device. There may be compromises in cost of manufacturing in order to support higher level of performance, but the team will explore other ways to avoid inflated costs.
- **Environmental factors** – Ensuring the definitive version of the snake robot is environment friendly in ways one can easily dispose of components and casings without causing harm to the surroundings. Proper monitoring, control and disposal of energy storing devices like the battery pack.
- **Safety** – Creating a user-friendly design which poses no risk of danger or harm to the operator, whether it involves electrical components like the battery or the external dimensions of the device. The device will feature a smooth exterior devoid of sharp edges as well as insulation for the battery unit and electrical wiring. Safety of workers, consumers, and the public.
- **Ethical** – Designs without considering safety and health of workers, consumers and/or the public. Products implicitly using patent protected designs/concepts. Products that can be used to secretly survey the personal and private life of the public. (Violation of privacy)

1.5. Report organization

- In the first chapter, the project is introduced and a summary of the technical aspects of the device, the overall significance, main objectives, and project constraints are discussed.
- The second chapter does a more in-depth review of snake robot prototypes, varying in terms of engineering design, functionality, and operation, developed over the years. It gives a background information and brief history of robotics research work in the field of bio-inspired robotics as well as bio mimicry.
- The third chapter elaborates on the proposed design and supplies a technical overview of the snake robot as well as the mechanical, electrical and software components used. Each of the main parts is listed with a summary of their operation, technical specifications as well as various numerical analysis. The numerical analysis includes motor calculations, power calculations, mechanical and physical properties of the 3D printed parts, MATLAB simulation of the motion model and dynamics as well as reliability analysis.
- The fourth chapter deals with the manufacturing of the snake robot. In this section the various manufacturing techniques will be discussed, for example, placement of electrical components, as well as the general mechanical assembly and material selection process of the snake robot. Design for manufacturability will be discussed in this chapter.
- The fifth chapter will focus on the testing methods to be implemented to ensure proper functioning of the snake robot under specific environmental conditions.
- Lastly, appendices will include details and reference to the electronic media used, project constraints, engineering standards, logbooks, project timeline, Gantt chart and detailed technical drawings.

CHAPTER 2 - LITERATURE REVIEW

2.1. Background information

Engineers and scientists have long worked to find inspiration from nature to develop products that harness its unique characteristics, which could prove to be particularly useful in the everyday lives of humans. However, one of the constraints that come in the way of the development of such a product is the fact that we cannot directly translate a natural, biological system into a mechanical or electromechanical system without making any compromise in performance, aesthetic, or even overall cost. In most cases, it is not workable to replicate a biological system as it is presented, rather we can extract and make use of specific aspects with our knowledge of engineering design, the constraints, and objectives in mind.

Table 1: Robots inspired from nature

Robot	Inspiration	Manufacturer	Type
Octobot	Octopus	Harvard University	Soft robot
Pleurobot	Salamander	École Polytechnique Fédérale de Lausanne	Quadruped
Cassie	Ostrich	Agility Robotics	Biped
Spot Mini	Dog	Boston Dynamics	Quadruped
Snakebot	Snakes	Carnegie Mellon University	Serpentine
Hexa	Crab	Vincross	Hexapod

This is the basic idea behind the field of bio-inspired design and snake robots are the electromechanical descendants of real snakes, and their mechanical structure, with the aid of a control unit, is optimized to perform a given task within predetermined boundary conditions. In contrast to nature, where snakes are capable of a variety of complex muscular movements and locomotion to execute a task, snake robots are only capable of performing their tasks with respect to the programming and data provided to them within their physical limitations. However, since engineers have the freedom to design what they desire, snake robots can be

improved beyond the normal operating conditions of a real snake. For example, real snakes are not capable of climbing ladders, but a snake robot developed under the supervision of Prof. Fumitoshi Matsuno in Kyoto University, Japan, can climb ladders using a unique gait programmed by the research team. This robotic snake is also capable of scaling drainpipes and other forms of complex obstacles in hopes that one day, as technology progresses, these robots can be used in disaster management scenarios for search and rescue missions.

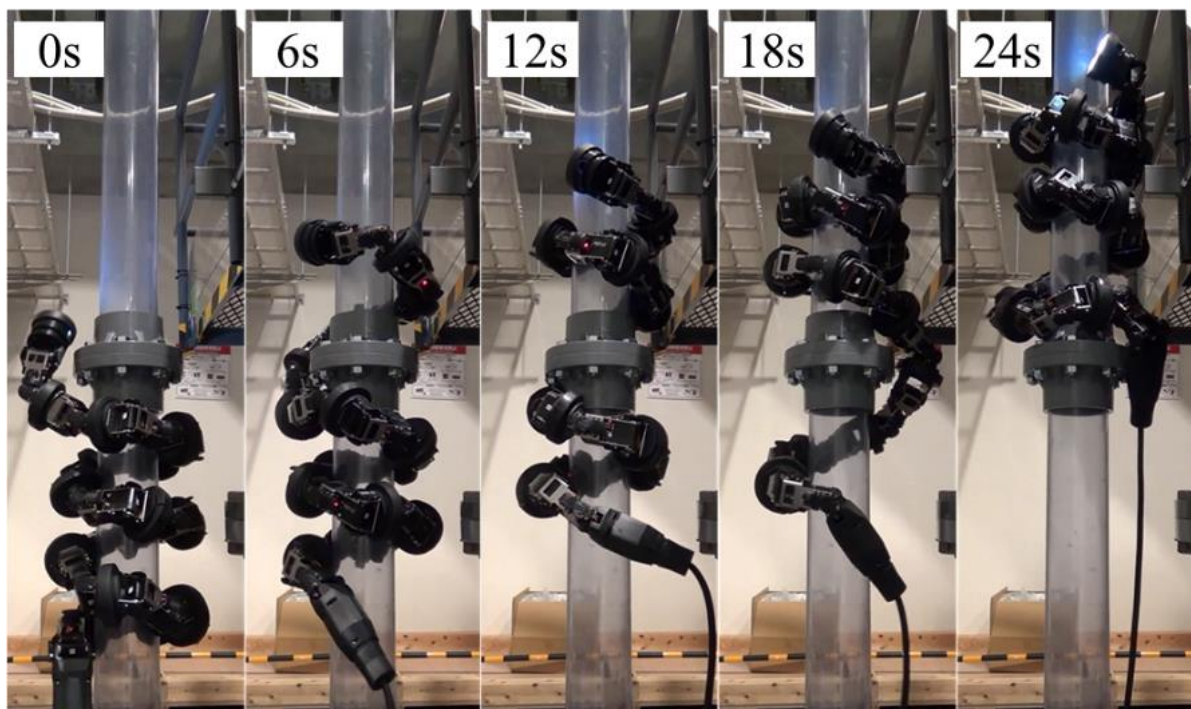

Figure 1: Snake robot developed in Matsuno Lab, moving over a flange.

Retrieved from ("Matsuno Lab Kyoto University - 蛇のページ," n.d.)

The first robotic snake was introduced to the world in 1972 by Prof. Shigeo Hirose and was known as the ACM (Active Cord Mechanism) III. This invention ushered in a new era of untapped potential in the field of bio-inspired robotics, which is the study of biological organisms in their natural environment to replicate specific physical characteristics and integrate them into engineering applications. The ACM III itself was a snake robot composed of 20 links, supported by passive wheels under each link, that were actuated by a servo system.

The robot was only capable of 2D motion according to (Hopkins, Spranklin, & Gupta, 2009); however, the sole purpose of this prototype was to provide Hirose with a perspective on various forms of snake locomotion and how he can further develop and prove the use of his serpenoid curve.

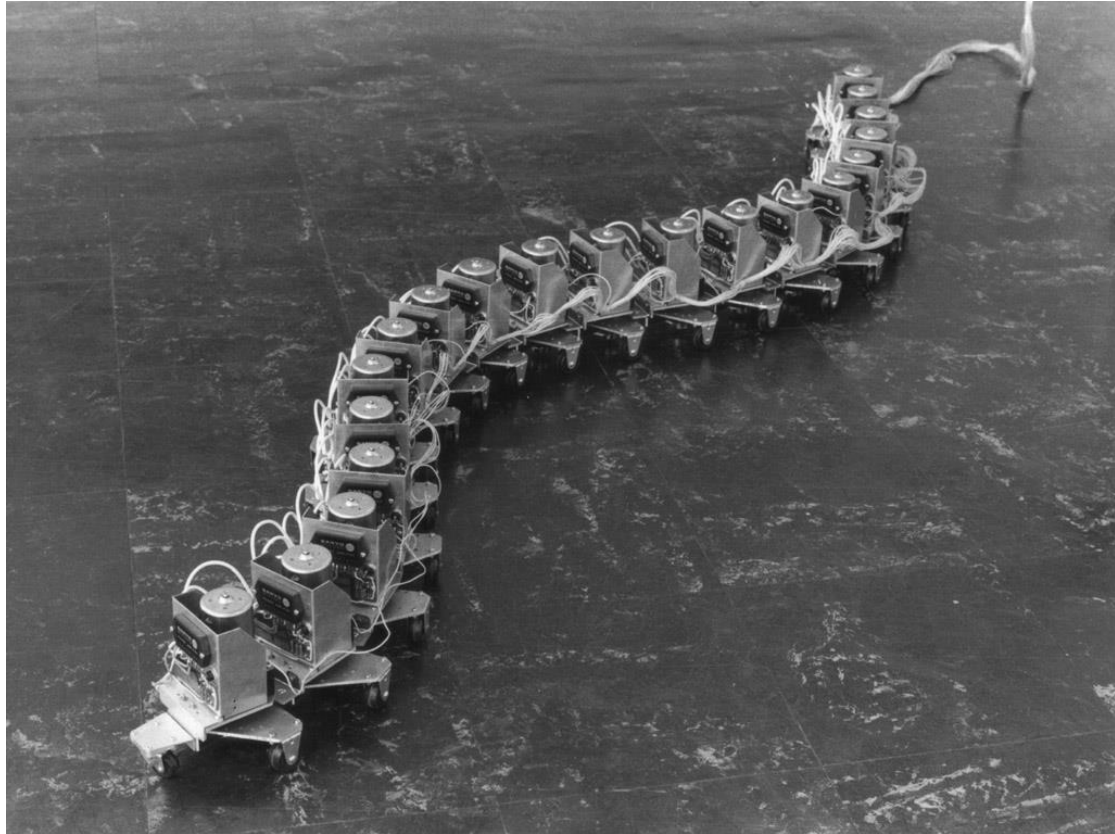

Figure 2: Active Chord Mechanism 3.

Retrieved from ("ACM-R5H - ROBOTS: Your Guide to the World of Robotics," n.d.)

The serpenoid curve is a mathematical model developed by Hirose which dictates the motion of a snake robot in close relation to that of real snakes. This curve function is widely used among snake robot prototypes today as well as to conduct various forms of motion and path planning for snake robots in general. Today, the snake robots developed in various research institutes and engineering establishments utilize the fundamental aspects of the ACM line of robots developed by Hirose and build on them by integrating more complex and modern

technology with more concentration in redundancy, modularity, manufacturability as well as practical applications in our everyday lives.

The ReBiS (Reconfigurable Bipedal Snake Robot) is an example of focus in achieving high modularity and maneuverability. The robot is able to move via three forms of gaits including serpentine gaits, transforming gaits and walking gaits. This implies that unlike the snake robots mentioned before, the ReBiS can alternate its mode of motion depending on the gait planner system between snake locomotion as well as walking motion. According to (Thakker, Kamat, Bharambe, Chiddarwar, & Bhurchandi, 2014a), each module of the robot is composed of mainly the Dynamixel MX- Robotic servo motor, a motor clamp and a C-bracket or C-link with the most abundant material being aluminum sheet metal. Unlike the circular or similar cross-section of typical snake robots, the ReBiS has a rectangular cross section in order to remain stable, especially during the bipedal motion. The axis of any given joint is orthogonal to the previous joint in order to ensure 3-dimensional movement. In order to achieve the distinct types of serpentine and bipedal movement, sinusoidal wave functions are applied to the motors in both the horizontal and vertical axes.

Variation in mathematical parameters like amplitude and phase difference, at a constant frequency result in lateral undulation, sidewinding, rolling as well as linear movement. The table below is an extract from the research work by (Thakker, Kamat, Bharambe, Chiddarwar, & Bhurchandi, 2014b) showing the values used in the sinusoidal function to achieve different gaits.

Table 2: Gait parameters

(Thakker et al., 2014b)

Gait	Parameters			
	Amplitude	Frequency	Phase Difference	ϕ
Lateral Undulation	$A_x = 60^0$ $A_y = 0^0$	$\omega_x = 5\pi/6$ $\omega_y = 5\pi/6$	$\delta_x = 2\pi/3$ $\delta_y = 0$	$\phi = 0$
Sidewinding	$A_x = 30^0$ $A_y = 30^0$	$\omega_x = 5\pi/6$ $\omega_y = 5\pi/6$	$\delta_x = 2\pi/3$ $\delta_y = 2\pi/3$	$\phi = 0$
Rolling	$A_x = 60^0$ $A_y = 60^0$	$\omega_x = 5\pi/6$ $\omega_y = 5\pi/6$	$\delta_x = \pi/2$ $\delta_y = \pi/2$	$\phi = \pi/6$
Linear Progression	$A_x = 0^0$ $A_y = 60^0$	$\omega_x = 5\pi/6$ $\omega_y = 5\pi/6$	$\delta_x = 0$ $\delta_y = 2\pi/3$	$\phi = 0$

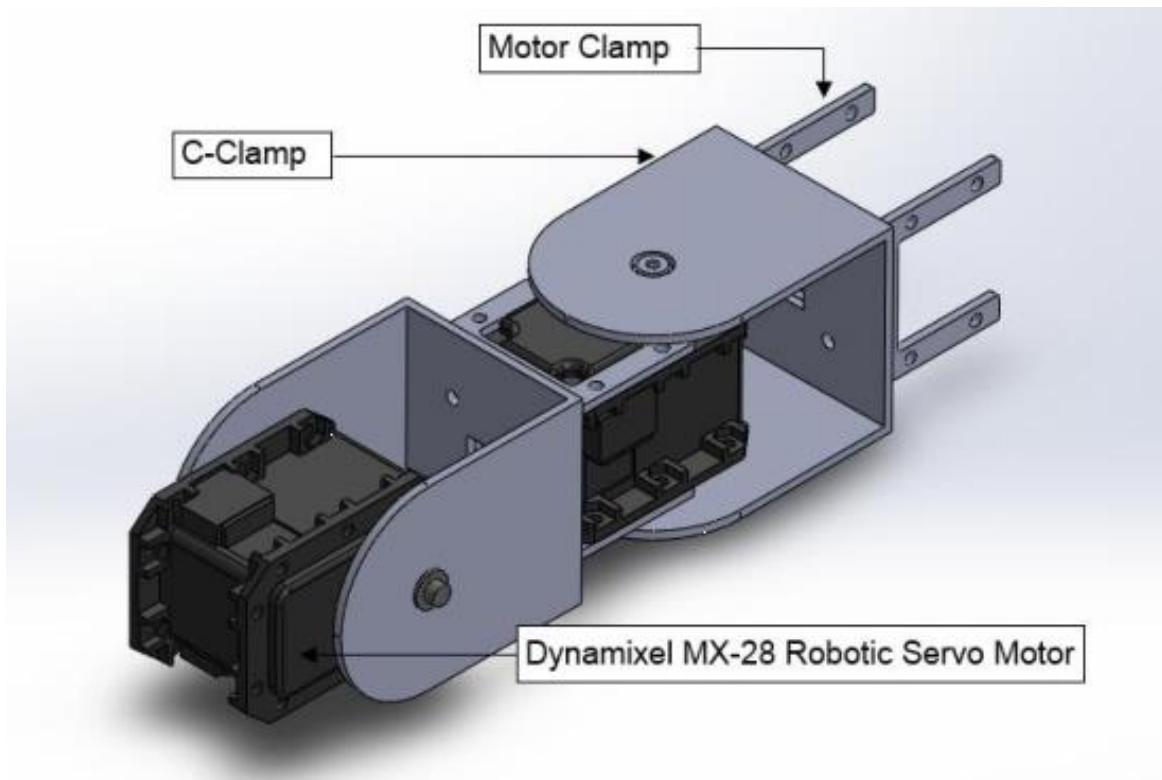

Figure 3: A module of the ReBiS snake robot with one joint orthogonal to the other.

(Thakker et al., 2014b)

2.1.1. Characteristics of snake robots

Modularity is defined by (“MODULARITY | Meaning in the Cambridge English Dictionary,” n.d.) as “the quality of consisting of separate parts that, when combined, form a complete whole”. Modular robots may be composed of slot, bus or sectional architectures. As defined by (Chen & Yim, 2016), a slot architecture can be visualized as a bus/component system where the interfaces of the bus and its components are distinct. The bus system is like a common bus consisting of parts with the same type of interface, unlike the slot type. Sectional architectures are those that consist of one component connected to another component, all featuring identical interfaces, rather than being connected to a common base component.

Most snake robots feature sectional modularity, and this proves to be a good advantage in terms of performance, reliability, and maintenance. In contrast to a manually adjusted modular system, a modular self-reconfigurable robot can take various shapes and orientations in a semi-automatic or automatic manner. With reference to an engineering article from (“MIT’s Modular Robotic Chain Is Whatever You Want It to Be - IEEE Spectrum,” n.d.), ChainFORM is a modular robot that allows the user to choose the number of base components they require at any given time. Each module is composed of a miniature servo motor, touch and angular sensors governed by a complex communication architecture developed by MIT in-house.

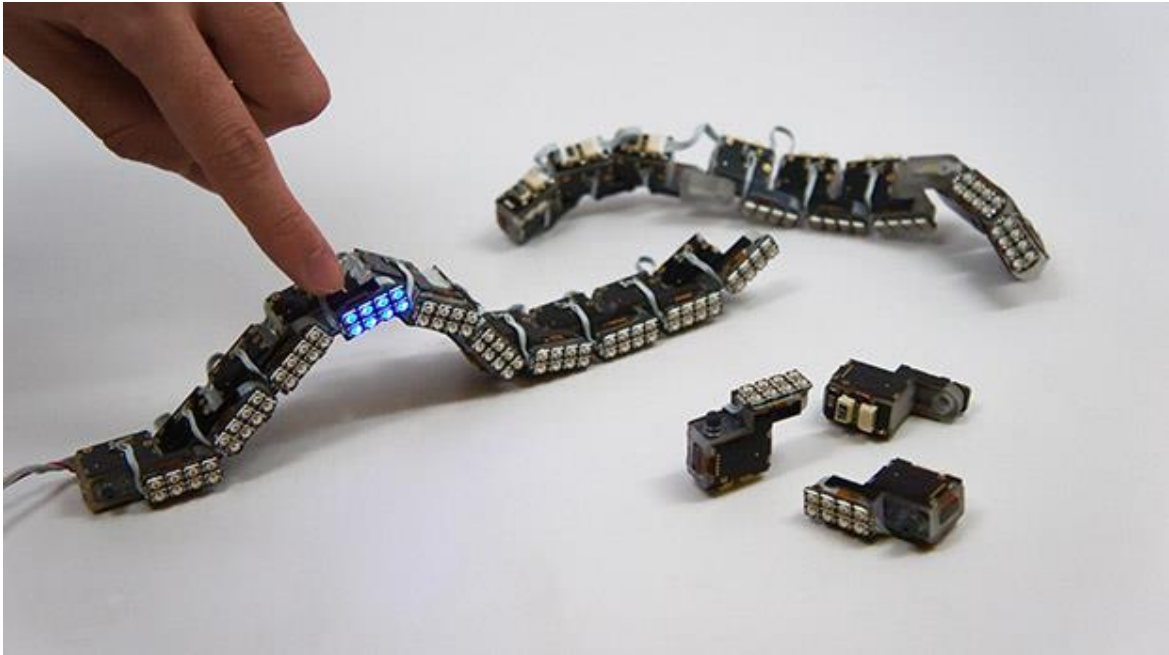

Figure 4: ChainFORM robot by MIT.

(“MIT’s Modular Robotic Chain Is Whatever You Want It to Be - IEEE Spectrum,” n.d.)

The design of such robots, inspired by nature also plays a significant role in its functionality in diverse environments including space. According to engineers at NASA (National Aeronautics and Space Administration) working on a snake robot, (*NASA - Snakebot*, n.d.), the flexibility and snake-like design of the robot will help reduce the overall weight of the space craft but at the same time have significantly no loss in terms of the tasks the robot can carry out. The lead engineer for this snakebot project, Gary Haith also mentions that such a robot design is field repairable. This is a pointer towards the modular designs that can be explored to reduce repair times of the snake robots. Instead of time-consuming processes to dismantle and repair specific components of a given modular snake robot, extra modules that can be simply switched can be designed by the team to account for possible failure scenarios.

The ability of a robotic snake to move is a function of the type of joint and interface used in its design. The types of joints used in connecting segments of the snake robots vary

according to the applications and objectives of a given project. The types of joints may include universal joints, torsion joints, telescopic joints, parallel mechanism joints as well as coupling joints, each contributing a unique mechanical quality to a snake robot design.

An example of a parallel mechanism joint can be seen in the works of (Li, Cao, Zhang, & Fu, 2016) where they integrated the concept encompassing Stewart platform manipulators in their snake robot. Stewart platform manipulators are 6 degree of freedom parallel manipulators designed for flight simulation in the 1980s. According to (Dasgupta & Mruthyunjaya, 2000), the Stewart platform initially started off with a triangular based to 3 actuation joints, but later iterations of the design influenced by other researchers featured a 6 joint actuation system. The research works of (Li et al., 2016) involve the use of the Stewart platform concept, in close relation to the muscular composition of real snakes, in the structural design of a snake robot. The work recognises the mechanical limitations of serially connected one degree of freedom robot joints and claims to ensure a significant increase in 3-dimensional performance via the use of their three degree of freedom bionic parallel mechanism.

The figure below is an extract from the research works of (Li et al., 2016) showing the fundamental motions that can be achieved in their 3 degree of freedom platform joint concept. The joint will be in default position as shown in (a). Translation (b) indicates the synchronised movement of the parallel actuators in a single axis along the length of the snake robot whereas pitch (c) and yaw (d) can be achieved via unique variations in each individual actuator.

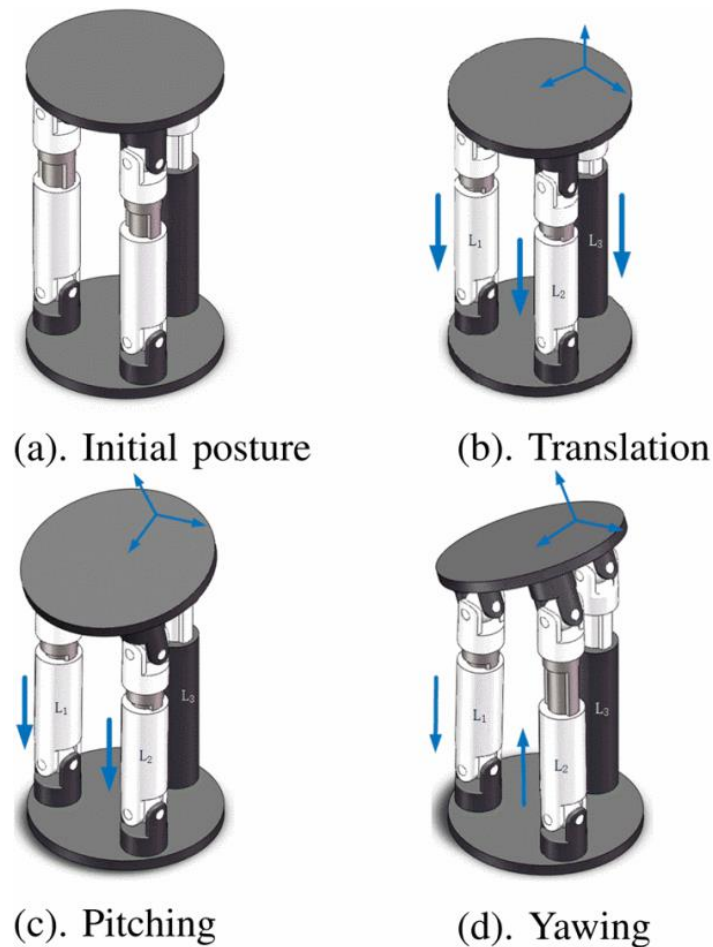

Figure 5: Different configurations of the 3-DOF parallel mechanism snake joint.

(Li et al., 2016)

This is an example of a redundant system, where if one joint fails, the snake robot will be able to function (although at a significantly lower efficiency) as compared to a serially design snake robot, where if one joint fails, the possibility of the entire snake failing to move is higher. It is also possible to design hybrid series-parallel systems and a good example of such a system is the human skeletal and muscular structure. The human arm for instance is serially composed of the shoulder joint connecting to the humerus (upper arm) which in turn is connected to the ulna and radius (forearm) as described in (“Human Skeleton | Parts, Functions, Diagram, & Facts | Britannica,” n.d.), all of this engulfed by a complex muscular and nervous structure. If the humerus were to fracture or get dislocated from the shoulder joint, being a

serial system, it will cause the rest of the arm to be completely immovable. In contrast to this, assuming damage only to the muscular tissues which are in a parallel configuration, the arm may still be able to operate with respect to the other undamaged muscles. Snake robots designed in a serial configuration are more common due to less use of components as well as lower overall cost.

The actuation system employed in snake robots vary from one design to another, although the most commonly used one comes in the form of either servo motors or DC motors. The main difference between a DC motor and a servo motor is that a DC motor is a continuous rotation motor that often employs coupled gear trains and various mechanical linkages relative to the snake segment in order to achieve the desired form of snake locomotion, whereas a servo motor is a high torque device according to (“What Is a Servo Motor and How It Works? | RealPars,” n.d.) featuring accurate rotation within a limited angle (usually 180 degrees).

However, snake robots are known to feature other unique forms of mechanical actuation like fluid actuation. Pneumatic actuators were more commonly used in early snake robot designs but hybrid systems employing the use of both fluid actuation and DC motors according to (Liu, Tong, & Liu, 2021) have opened a path to exploring better forms of snake locomotion. The OmniTread OT-4 is a good example of a snake robot using a hybrid actuation system. With respect to the works of (Borenstein, Hansen, & Borrell, 2007), the OmniTread OT-4 is composed of a centralized motor segment which contains a DC motor and several other segments comprising of pneumatic actuators that sum up the 7 segments of the snake robot. The figure below shows the arrangement of all the segments in the Omnitread OT-4.

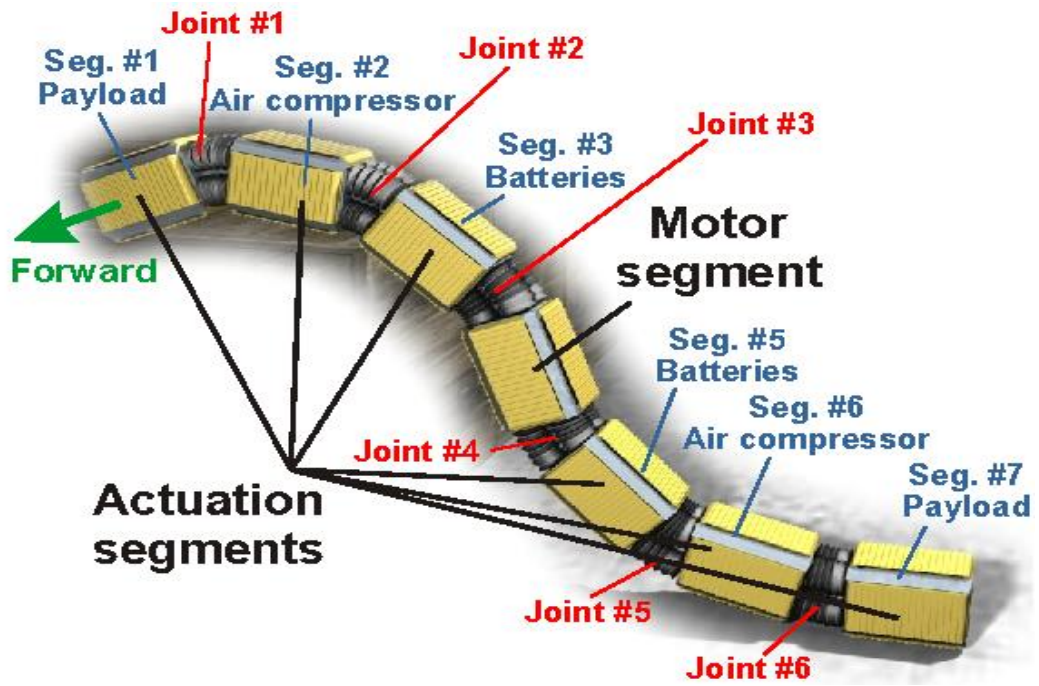

Figure 6: The arrangement of segments in the OmniTread OT-4.

(Borenstein & Borrell, 2008)



Figure 7: OmniTread OT-4 held by user for size comparison.

("Chap 1: OmniTread," n.d.)

This robot uses active tread system encompassing all sides of the segments therefore the movement of the snake robot is not impeded regardless of its orientation as compared to the ReBiS snake robot discussed earlier. The main aim surrounding the use of active treads around the robot focus on the unavoidable rolling nature of typical snake robots in uneven, obstacle littered environments. Other types of snake robots employ active or passive wheel mechanisms and may also directly depend on friction for motion, devoid of wheels.

2.2. Concurrent Solutions

Four different snake robot prototypes were studied and summarized in the section below. The designs were obtained from online sources and are on-going open-source projects in some cases. The concurrent solutions are as follows.

2.2.1 *Bio-inspired Robotic Snake*

The project as shown in figure 8 below is inspired from a real-life sidewinder snake and uses serpentine motion. This is one of 2 designs developed by Donaldson, the other being the 1D snake robot design. This prototype relies on an Arduino microcontroller but cannot be remotely controlled by the user. The robotic snake consists of 10 segments actuated by servo motors in a 2D axis configuration where each motor is rotated 90 degrees compared to the previous. This allows 5 servo motors to control their respective segments in the x axis and the other 5 servo motors in the y axis. The combination of these two orientations with respect to the relevant programming results in the 2D motion of the bio-inspired snake robot.

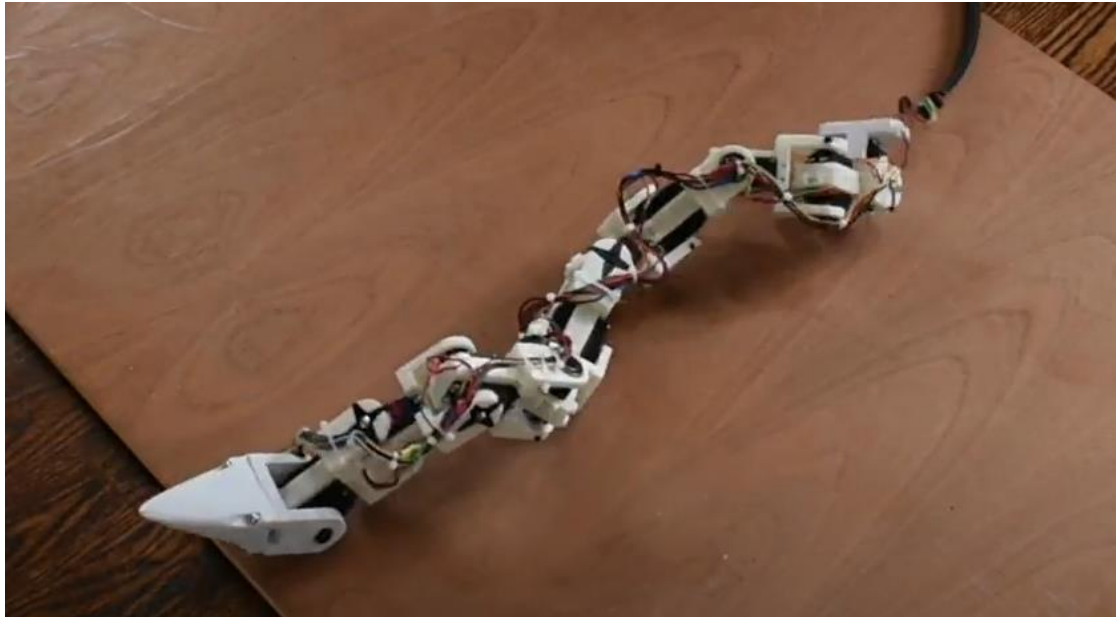

Figure 8: 2D Axis Bio-inspired Robotic Snake

(“Bioinspired Robotic Snake : 16 Steps (with Pictures) - Instructables,” n.d.)

The robot does not feature a power supply unit inside the chassis rather the power is supplied from an external variable source. Donaldson, the designer of this snake robot, mentioned that he wishes to modify the design of the robot by adding a separate power module in which he can house a LiPo battery to power the snake. This will allow the robot to be fully independent of power cables or external wiring, promoting better movement.

2.2.2. Reconfigurable Robot Snake

The reconfigurable snake robot shown in figure 9 is capable of several different modes of snake locomotion and they include slithering, inch worm motion, sidewinding and rolling (with the aid of passive wheel mechanism placed below each segment of the snake robot). It includes 12 segments actuated by servo motors with an Arduino microcontroller and key fob that provides remote control for the snake. It also features autonomous movement.

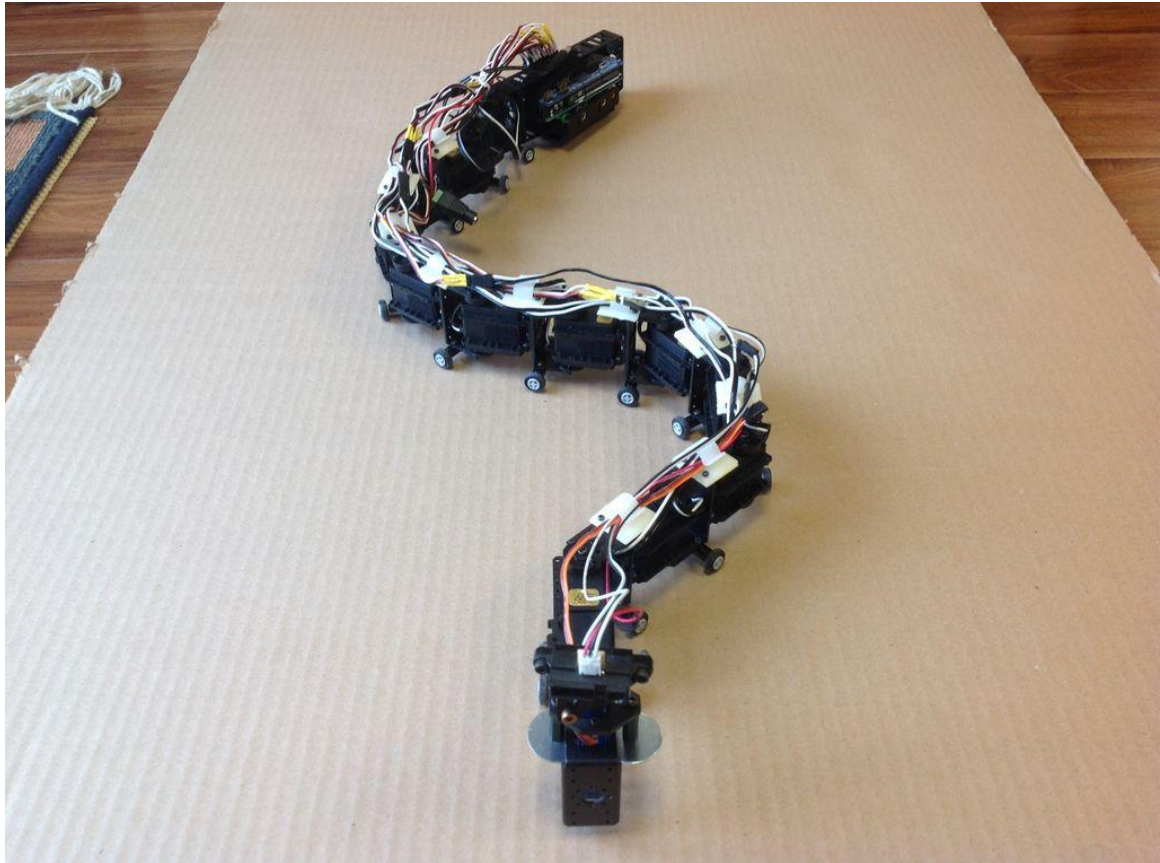

Figure 9: Reconfigurable Robot Snake
("Snake Robot : 7 Steps (with Pictures) - Instructables," n.d.)

2.2.3. Carnegie Mellon University Snake Robot

This snake robot is composed of 16 aluminum modules in a series configuration with each module rotated 90 degrees with respect to the previous module in order to achieve 3D motion. Materials with high friction are also attached to the snake robot in form of a skin in order to allow more efficient movement. According to (Wright et al., n.d.), the robot is powered by Hitec HS-5955TG servo motors housed in a custom 3D printed U-case, which allows one degree of freedom per module.

The range of motion of each module is limited to 180 degrees. PID is used to control and monitor the module position and a magnetic encoder for position feedback. The PID controller was developed in-house by the research team. The snake robot features a camera

module in the head for monitoring and surveying purposes. The motion modelling and gait planning described by (Enner, Rollinson, & Choset, 2012) is as complex as the mechanical architecture of the snake robot but can be used within other snake robot designs as well. The figure below shows the snake robot in action.



Figure 10: Snakebot clinging to a pipe.

(“Snake Robots Crawl to the Rescue, Part 1 - ASME,” n.d.)

2.2.4. DIY Smart Snake Robot

As shown in figure 11 on the next page, this snake robot contains 12 segments motivated by servo motors. Servo control is provided by Arduino and android app using Bluetooth. It also has capable of autonomous movement. The feature is that distinguishes it from others is slithering movement does not exist. Instead, movement is ensured by two passive wheel mechanisms located below each segment of the robot.



Figure 11: DIY Smart Snake Robot

(“Arduino Based Snake Robot Controlled Using Android Application Project,”
n.d.)

2.3. Comparisons of the Concurrent Solutions

In the following section, all the concurrent solutions summarized above will be discussed properly with help of the Pugh’s Matrix for the team to understand which design is the most suitable for this project with the project aims in mind.

- **Bio-inspired Robotic Snake** – Bio-inspired Robotic Snake is a type of robot consisting of 10 joints. Arduino is used as the main board and due to the relatively compact size of the robot it can move quickly and flexibly. Plus, its cost is much more affordable than other robots available on the market. The disadvantage is the lack of a remote-controlled system. The robot moves only according to the code written and no movement command can be sent while the robot is running. For this reason, the action to be performed must be

determined beforehand, coded and then robot must be run, which requires the robot's movements to be coded repeatedly each time. This is a very tedious task and may not prove to be particularly useful for surveying environments that tend to vary heavily.

- **Reconfigurable Robot Snake** – This is a 12-joint type of robot featuring 4 different modes of locomotion (slithering, inch worm, sidewinding and rolling). With the help of a remote-control system, the robot can be moved according to the desired commands while it is running, unlike the bio-inspired robot that must be reprogrammed each time before executing a certain motion. In addition, it can work autonomously. These properties make the mechanical and electrical infrastructure much more complicated than other types of snake robots. A bulkier servo motor is used, and the system also has an independent module to house the electrical power unit. This is an advantage over the bio-inspired robotic snake as it does not require an extension cord protruding from the robot to the power supply. The main disadvantage can be a shorter mission time, as the power unit has limited capacity per run and needs to be replaced or charged before every mission. These disadvantages make cost high, although it can be used in many places as a usage area.
- **Carnegie Mellon University Snake Robot Project** – Most of the snake robots summarized in the concurrent solutions draw inspiration from this prototype. Composed of 16 modules in relation to high torque servo motors, this robot is capable of climbing the external and internal sections of pipes and later iterations of the robot is able to swim (“CMU’s Snakebot Goes for a Swim,” n.d.).
- **DIY Smart Snake Robot** – This is a 12-joint robot. There are autonomous and remote-control options. The biggest shortcoming is the lack of slithering motion. Wheels are used instead. Usage of wheels has greatly restricted the robot's mobility. These limitations of movement on different surfaces caused by the wheels are the biggest disadvantage of the

robot, although it is seen as an advantage to control it through the Android application and to supply autonomous movement as well.

In this table, the team compared 4 different concepts using PUGH's Matrix. The team is looking for a low cost but reliable snake robot with relatively small weight but good stability when in motion. But the weight will depend on the type of materials used for the shell, which will be determined in the later sections. An environmentally friendly and sustainable product is envisioned as well.

Table 3: PUGH's Matrix for snake robot concept selection

Concept 1→Worst 10→Best	Bio-inspired Robotic Snake (C1)	Reconfigurable Robot Snake (C2)	CMU Snake Robot (C3)	DIY Smart Snake Robot (C4)
Cost	8	4	2	4
Reliability	8	6	9	4
Weight	10	4	8	6
Environment Friendly	10	10	10	10
Stability	8	6	9	2
Sustainability	8	6	8	2
Score	52	36	46	28

The team decided on concept C1 during meeting minutes. Concept C1 was decided as the most suitable for our purpose because of reduced cost, less weight, high stability and high sustainability properties. Also, the team plans to improve the design of concept C1 by making the snake longer for better movement as well as installing a camera module, all of which is controlled via an infrared remote-control system. The next best alternative was the CMU Snake robot, but the team decided against this due to the prohibitive cost of materials and components

used in this project and the excessive cost of build, since this snake robot project is also based on design for cost.

Table 4: PUGH's Matrix for selecting axes of snake robot

Concept 1→Worst 10→Best	Single Axis Bio- inspired Robotic Snake (C1C1)	Double Axis Bio-inspired Robotic Snake (C1C2)
Cost	8	8
Reliability	8	8
Weight	10	10
Environment Friendly	10	10
Stability	6	8
Sustainability	8	10
Score	50	54

During the meeting discussions, the comparison of the two types of Bio-inspired Robotic Snake was decided according to their axis of motion. C1C2 which is double axis (2D) Bio-inspired Robotic Snake was selected which is highly stable and highly sustainable. Furthermore, a 2D axis is the base requirement for the team to build a snake robot that is physically capable of surveying various environments.

The following matrix shows how the team decided on the C-bracket material to be used for the joints in the snake robot.

Table 5: PUGH's Matrix for bracket selection

Concept 1→Worst 10→Best	Aluminum Matte Coat Servo mount bracket (C1C1a)	3D-Printed *PLA+ filament bracket (C1C2b)
Cost	8	5
Reliability	8	8
Weight	6	10
Environment Friendly	6	10
Stability	8	8
Sustainability	6	8
Score	42	49

Concept C1C2b was chosen by team for the material of the joint of Snake Robot according to less weight and higher sustainability. Also, we decided that the use of PLA+ filament in our 3D parts will be more environment-friendly despite a slight increase in the cost of the operation. Concept selection of the filament discussed in Chapter 4: Manufacturing Plan.

Table 6: PUGH's Matrix for servo motor selection

Concept 1→Worst 10→Best	MG995 Servo Motor (Ca)	MG996R Servo Motor (Cb)
Cost	10	10

Reliability	4	8
Weight	10	7
Environment Friendly	10	10
Stability	6	8
Sustainability	6	8
Score	46	51

According to servo motor comparison between MG995 and MG996R, concept Cb which is MG996R Servo Motor type has been selected. It is highly recommended because of the following properties: stability, sustainability, and reliability.

2.4. Engineering standards of the concurrent solutions

- ISO 128-21: Technical Drawings — General principles of presentation: art 21 Preparation of lines by CAD systems.
- ISO 13482:2014: Robots and robotic devices — Safety requirements for personal care robots.
- ISO/DIS 10218-2 ROBOTICS — Safety requirements for robot systems in an industrial environment — PART 2: Robot systems, robot applications and robot cells integration.
- ISO 8373:2012 Robots and robotic devices — defines terms used in relation with robots and robotic devices operating in both industrial and non-industrial environments.
- ISO/IEC DIS 23510: Information technology — 3D Printing and scanning — Framework for additive manufacturing service platform (AMSP).

CHAPTER 3 - DESIGN AND ANALYSIS

In this section, selected design of Bio-inspired Snake robot will be discussed. Relevant calculations and standards for this design will be explored. After all, cost analysis of the project with all details will be given.

3.1. Proposed/Selected Design

Selected design is a Double Axis Bio-inspired Robotic Snake shown in figure 12 which is developed with respect to two fields, electronics, and control system of the snake robot, respectively. Mainly the electronics parts consist of the servo motors connected in parallel, an infrared sensor with emitter and receiver, governed by the Arduino Uno. The control system of the snake robot is comprised of an infrared remote controller which sends signals to the Arduino Uno via the infrared receiver. The mechanical and electronic architecture of the snake robot is shown on figure 13 and 22 respectively.

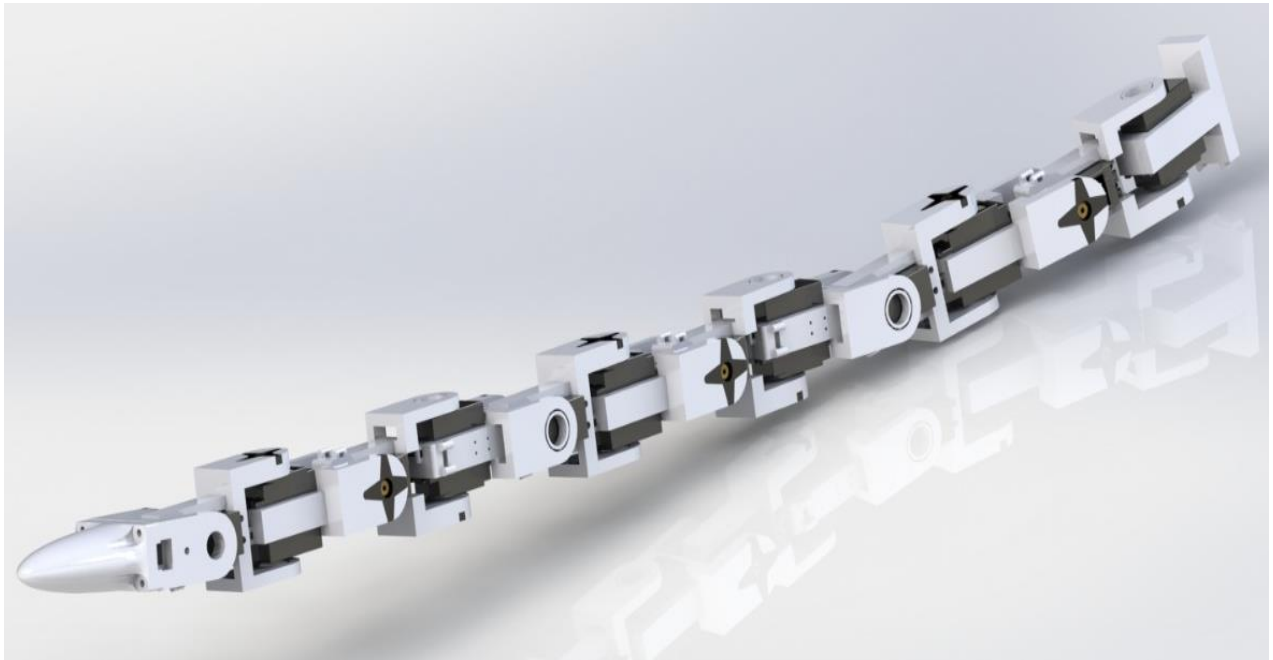

Figure 12: 3D rendering of snake robot prototype

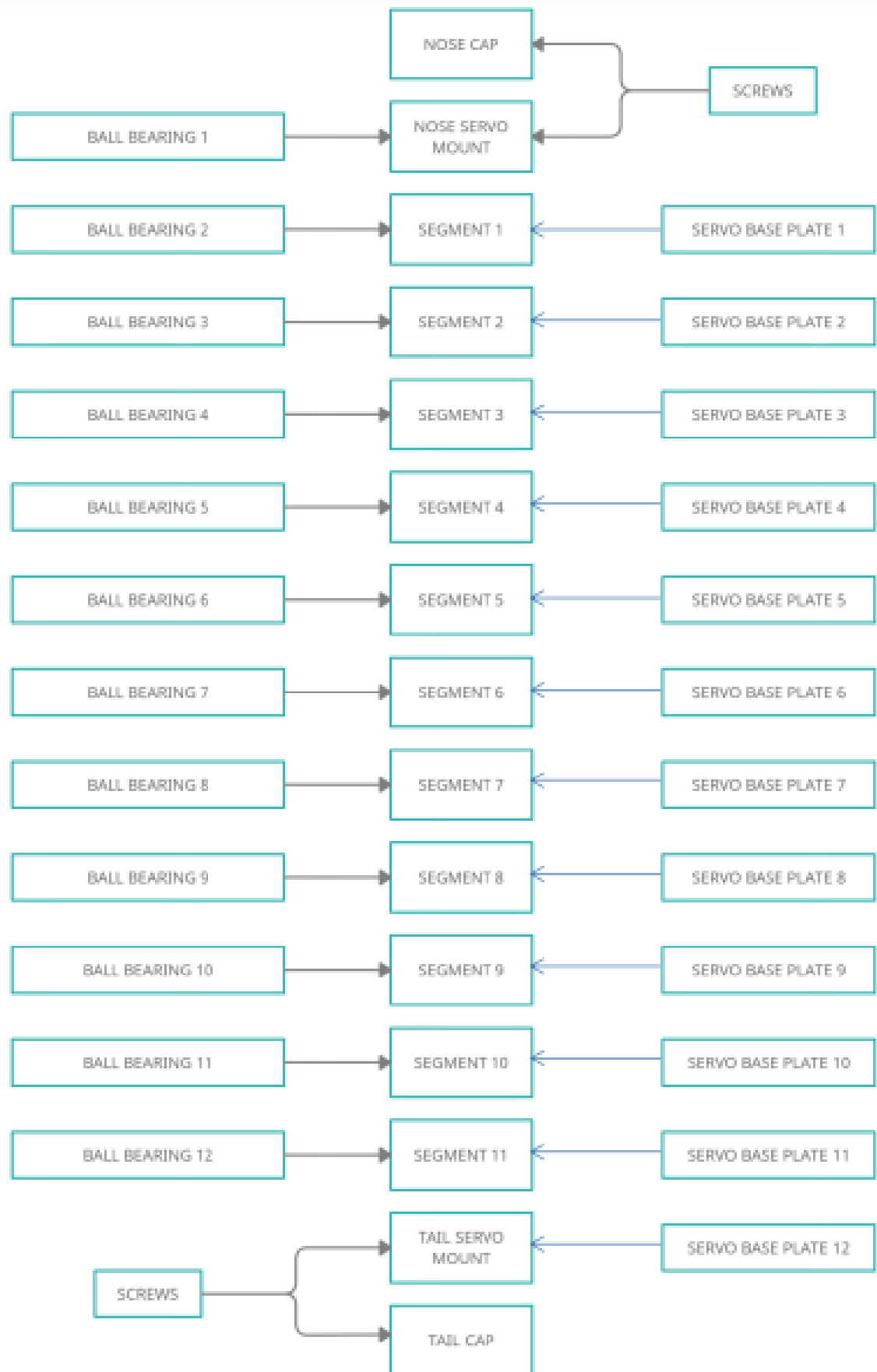

Figure 13: Mechanical architecture of the snake robot

Main components of the Bio-inspired Snake Robot include:

1. Joints
2. Servo motors
3. Electronic Components
4. Wi-Fi Camera
5. Remote Controller

3.1.1. Joints

Each segment of the snake robot that forms the entire chain is connected via 3D printed joints as shown in the figures below. There are three types of joint designs used: the 2D servo mount (Figure x) the nose servo mount (Figure x) and the tail servo mount (Figure x). The 2D servo joints mainly aid in the movement of the snake robot via servo output shafts that are connected to one end of the joint while the other end is attached to a dual sealed miniature ball bearing. The 2D servo segment housing a servo motor inside, will allow the robot to move by generating friction forces between it and the surface, is the most common and repeated segment used along the entire mid-section of the snake robot. On the other hand, the nose servo mount has the same applications as its variant but is unique to the head of the snake and features a housing and connection for the head servo. The tail servo mount will house the Arduino Uno microcontroller and will feature a small hole at the tip allow the external power supply cable to attach. There is a plethora of materials that can be used to create a joint and, in this project; PLA+ filament joints were selected.

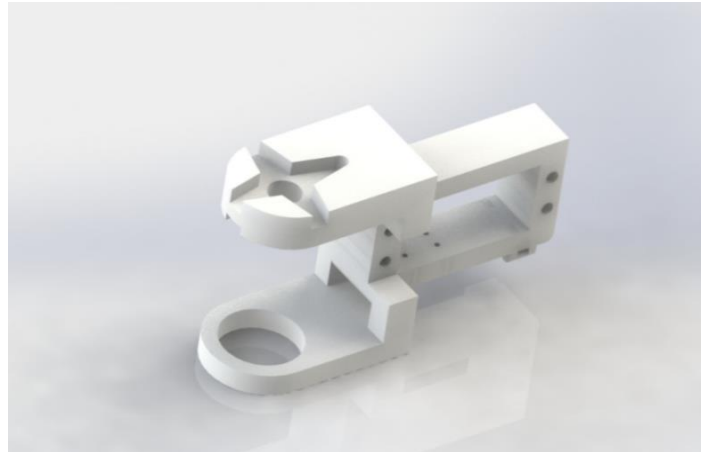

Figure 14: 2D servo mount design



Figure 15: Nose servo mount design



Figure 16: Tail servo mount design

3.1.2. Servo motor

The Tower Pro MG-996R Servo Motor was selected for the snake robot. It features metal gearing which in turn results in large stalling torque. Also, this high torque servo motor can rotate 60 degrees in each direction. It's an upgraded version of the MG995's Servo motor for applications that require shock-proofing as well as in PCB and IC control system fields. These three upgrades also make the MG-996R a more accurate component. It is best to use a servo motor with metal gears in the case of high torque applications because of their high load bearing characteristics and reliability.

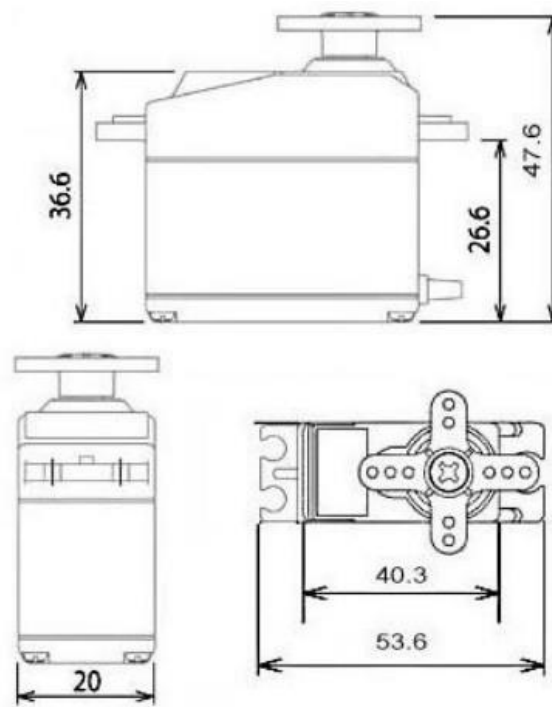
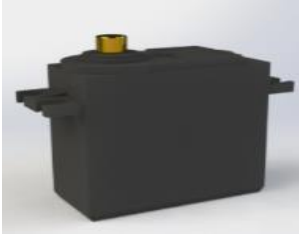
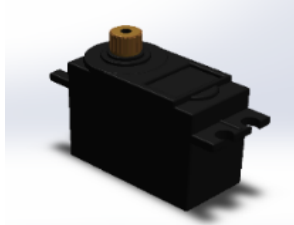

Figure 17: Dimensions of the MG-996R

(MG996R High Torque Metal Gear Dual Ball Bearing Servo, n.d.)

The comparisons of the MG-995 and the MG-996R are shown in table 6, in the concept selection phase. The table below shows the engineering change order as prepared, checked and approved by the project team members. Details of the technical specifications of the servo motor selected can be found in Appendix F.

Table 7: Engineering Change Order for servo motors

Engineering Change Order	
Design Organization:	Date: 09.05.2021
Subject of change: Servo Motor Design Selection	
Reason for change: Dimension and Stall Torque	
Description of change (Attach drawings as needed): (Ca) Dimensions: 40.4 x 19.9 x 37.5 mm, Stall torque: 9 kgf.cm	
	
(Cb) Dimension: 40.4 x 19.7 x 42.9 mm, Stall torque: 11 kgf.cm	
	
<input type="checkbox"/> Bill of material <input checked="" type="checkbox"/> Work in progress <input type="checkbox"/> Inventory <input checked="" type="checkbox"/> Design report <input type="checkbox"/> Instruction manual <input type="checkbox"/> Other:	Team Member: Abdulrahman Saber Ali Mahfoodh
	Team Member: Muratcan Yüce
	Team Member: Shah Mohammed Isfar
	Prepared By: Muratcan Yüce
	Checked By: Shah Mohammed Isfar
	Approved By: Abdulrahman Saber Ali Mahfoodh
The Mechanical Design Process Designed by Professor David G. Ullman Copyright 2008, McGraw-Hill Form # 26.0	

3.1.3. Electronic Components

The electronics components can be further divided into the Arduino UNO microcontroller, the external power supply. A summary of their application and description is given below.

- **Arduino UNO** – Arduino UNO is a microcontroller board based on the Microchip ATmega328P. It has 14 I/O digital pins (6 PWM output) and 6 I/O analog pins. Arduino UNO has been chosen because of its low cost, enough number of I/O pins and easy-to-use for this project. The figure below shows the schematic of the Arduino Uno and each of its integrated parts and sections. The analog reference pin at the top section of the board is shown in orange whereas the ground is in light green followed by pins 2 to 13 in green. Digital pins 0-1/Serial In/Out-TX/RX is in dark green, reset button (S1) in dark blue, In-circuit serial programmer in blue-green, analog in pins in light blue, power and ground in orange at the bottom next to external power supply and USB power in pink and yellow, respectively. Arduino Mega was employed for the snake robot because it has a bigger pinout than the Arduino Uno. However, the Arduino UNO is still capable of performing according to the objectives of the snake robot.

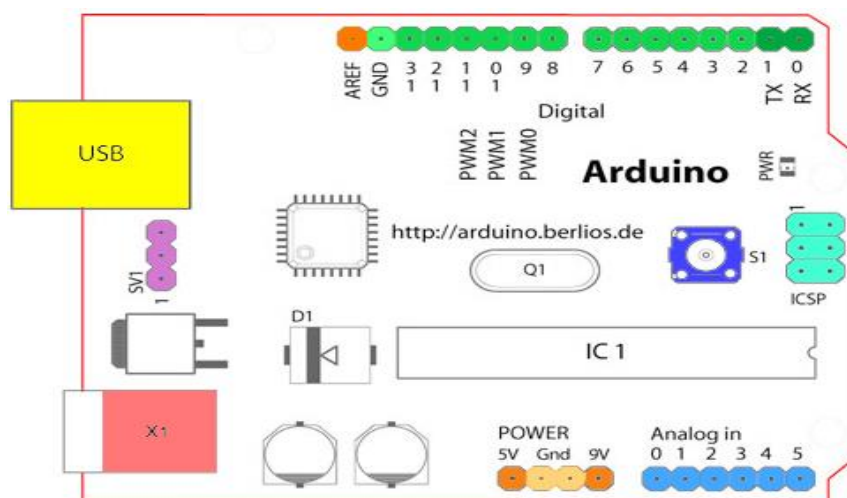

Figure 18: Arduino UNO board and names of each part on the board.

(“Arduino - Board,” n.d.)

- **Power Supply** – The KXN-3020D Adjustable Power Supply will be used to provide electric power to the snake robot. Despite the use of an external power supply demands too much cable for connection and range, Unlike LiPo batteries, an external power supply will not require the design of a separate module or housing in the snake segment thus reducing the overall number of components used in the snake robot itself. This promotes reliability and increases the mission time of the snake robot but with a small compromise in range of operation. In addition, because the power supply's voltage and current are adjustable, it allows that snake robot to be tested within the normal operating conditions of the current components in use. If for example, in future models of the snake robot the current servo motors are replaced with servo motors with significantly higher rating, or expanding on the number of servos used, then the power can be simply adjusted rather than completely replaced in the case of LiPo batteries.



Figure 19: KXN-3020D Adjustable Power Supply
(“Power Supply,” n.d.)

3.1.4. Wi-Fi Camera

OV7670 type camera module has been used and assembled in head of the snake to allow the user to remotely explore the environment, one of the primary purposes of the snake robot. According to the device datasheet, it features a low voltage CMOS sensor capable of delivering the complete functionality of a single-chip VGA camera and image processor in a very compact package. It can hand over complete user control in terms of image quality, formatting as well as the transfer of the data output with the added benefit of eliminating common sources of image contamination, using fixed pattern noise (FPN), like lighting and electrical factors. This type of camera module is also preferred because it has 640 x 480 VGA resolutions with up to 30 frames per second and requires an operating range between 1.7 V to 3 V power supply I/O. More technical information regarding this camera module can be found in the device datasheet in the appendix section.

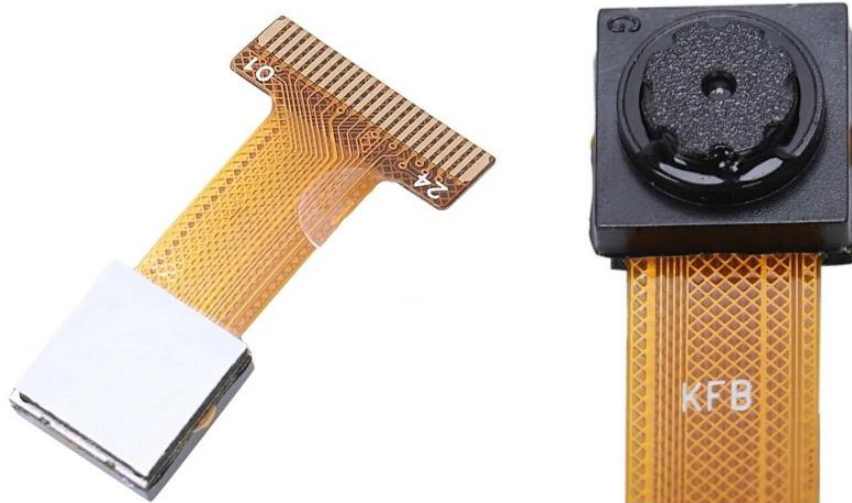

Figure 20: OV767 type Wi-Fi Camera module.

("0.3MP OV7670 Camera Module with High Quality SCCB Connector – Gona Kart," n.d.)

3.1.5. Remote Controller

All systems will be controlled by an Infrared Remote Controller. The basic premise of IR control is to carry signal between the remote control and snake through light path. IR remote controller sends pulses of infrared light indicating special codes. In other words, every button on the remote has a unique type of binary number which corresponds to a preprogrammed action to be executed by the snake robot.



Figure 21: IR Remote Controller.

(("Use an IR Remote Transmitter and Receiver with Arduino - Arduino Project Hub," n.d.)

Every button on IR Remote Controller and their explanations are given as follows:

1. Start-Stop: When pressed once, starts the Snake Robot. Electric power will pass through all system. When pressed twice, it cuts the electric power on the robot. Robot will stop without delaying.
2. +: Allows movement in forward direction.
3. -: Allows movement in backward direction.

4. >>: Allows movement in right direction.
5. <<: Allows movement in left direction.

There are also 5 modes of movement of snake robot.

- **Mode 1:** Slithering motion mode is activated when button 1 is pressed.
- **Mode 2:** Sidewinding motion mode is activated when button 2 is pressed.
- **Mode 3:** Rolling motion mode is activated when button 3 is pressed.

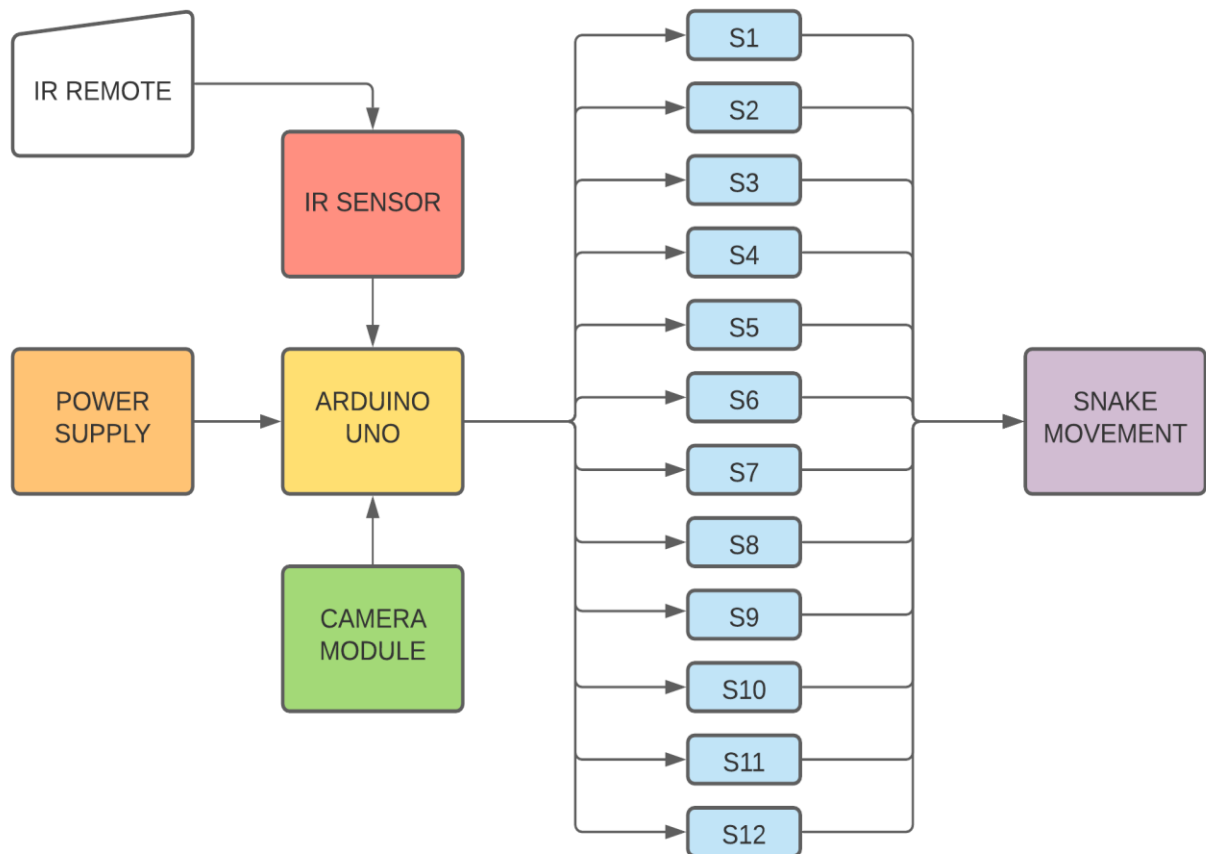

Figure 22: Electronic architecture of the snake robot. S1 to S12 represent the servo motors

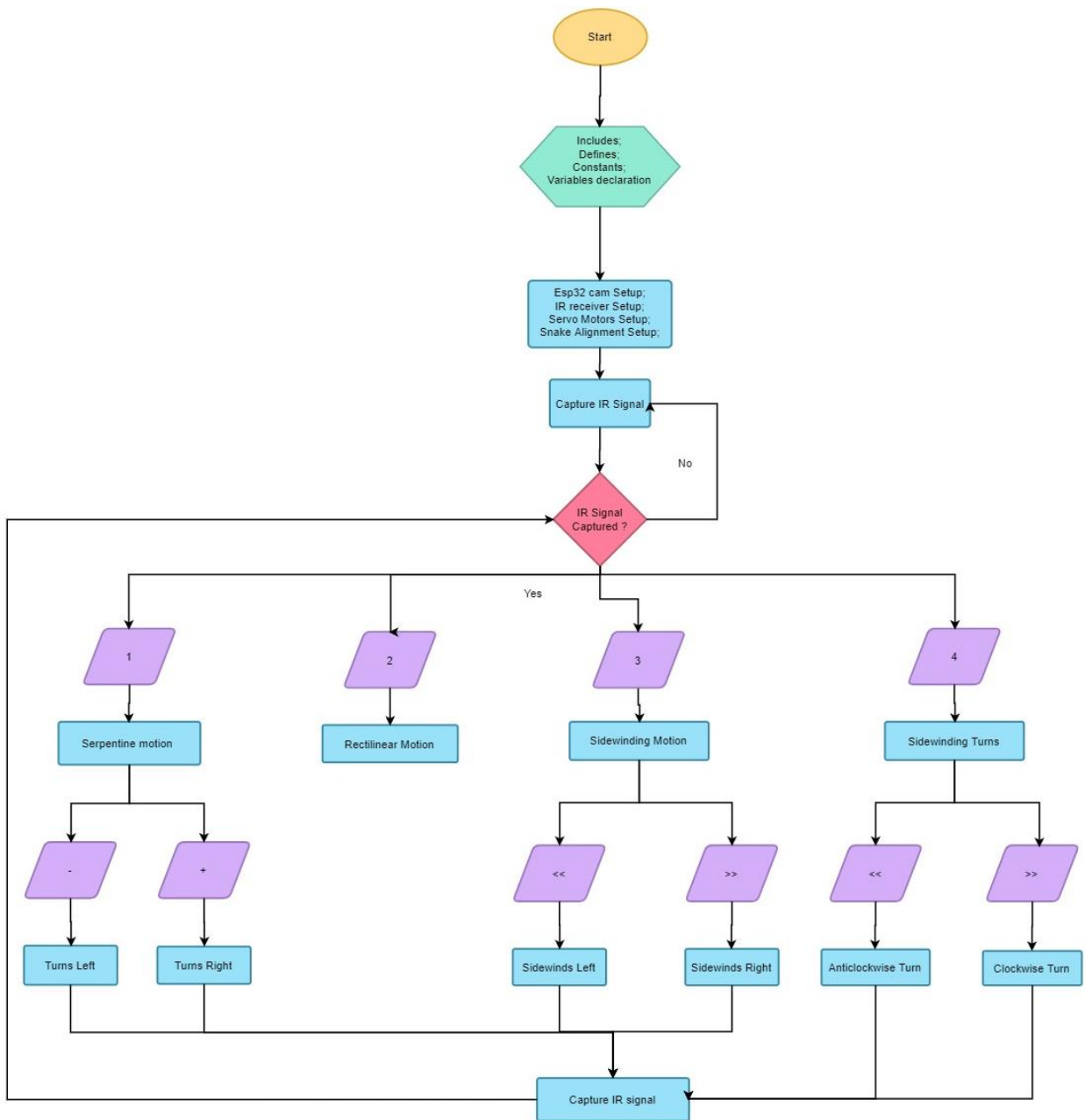

Figure 23: Program flowchart

3.2. Engineering Standards

- ASTM E2521-16 Standard Terminology for Evaluating Response Robot Capabilities
- ASTM E2566-17a Standard Test Method for Evaluating Response Robot Sensing: Visual Acuity
- ASTM E2804-11(2020) Standard Test Method for Evaluating Emergency Response Robot Capabilities: Mobility: Confined Area Obstacles: Stairs/Landings
- ASTM E3132/E3132M-17 Standard Practice for Evaluating Response Robot Logistics: System Configuration
- ASTM E2992/E2992M-17 Standard Test Method for Evaluating Response Robot Mobility: Traverse Sand Terrain
- ASTM E2991/E2991M-17 Standard Test Method for Evaluating Response Robot Mobility: Traverse Gravel Terrain
- ASTM E2827/E2827M-20 Standard Test Method for Evaluating Response Robot Mobility Using Crossing Pitch/Roll Ramp Terrains
- ASTM E2801-11(2020) Standard Test Method for Evaluating Emergency Response Robot Capabilities: Mobility: Confined Area Obstacles: Gaps
- ASTM E2803-11(2020) Standard Test Method for Evaluating Emergency Response Robot Capabilities: Mobility: Confined Area Obstacles: Inclined Planes

3.3. Design Calculations

3.3.1. Servo Motor Calculations

12 Servo motors have been integrated into this snake robot. From MG996R datasheet specifications shown in table 8, one servo motor has a 5V operation voltage approximately. 12 such servo motors will be connected to each other in a parallel configuration. In this case, every servo motor has a 5V operation voltage connected to each other. Again, with respect to table 8, the running current of each servo motor is 900 mA, therefore when the number of servos is multiplied by running current for a single servo, it will give the resultant ampere value the snake robot requires.

Table 8: Servo Motor Specifications

Mass (gr)	55
Dimension	40.7 x 19.7 x 42.9
Stall torque (kgf.cm)	<ul style="list-style-type: none">• 9.4 at 4.8 V• 11 at 6 V
Operating speed (s/)	<ul style="list-style-type: none">• 0.17 at 4.8 V• 0.14 at 6 V
Operating voltage (V)	4.8 to 7.2
Running Current (mA)	500-900 at 6V
Stall Current (A)	2.5 at 6 V
Dead band width (µs)	5
Temperature range	C to C

Given the following normal operating conditions,

$$\text{Operation voltage } (V_o) = 5V$$

$$\text{Operation current } (I_o) = 900 \text{ mA} = 0.9 \text{ A}$$

$$\text{Number of servo motors } (n) = 12$$

$$\therefore I_R = n \times I_o = 12 \times 0.9A = 10.8A, \text{ where } I_R = \text{Resultant current} \quad (3.3.1)$$

Therefore, the resultant power (P_R) of the snake robot is equal to the resultant current (I_R) multiplied by operation voltage (V_o).

$$P_R = I_R \times V_o = 10.8A \times 5V = 54W \quad (3.3.2)$$

From the above calculation, it is concluded that the snake robot requires an excess of 54 watts of power for normal operation.

In AC motors, the angular velocity is multiplied by the motor torque when calculating the power.

$$T = \frac{P_R}{\omega_r} = \sqrt{3} \times V_o \times I_R \times \text{Cos}(\varphi) \quad (3.3.3)$$

$$\text{given that } w = 0.14 \frac{s}{60^\circ},$$

$$x = \frac{0.14 \times 360^\circ}{60^\circ} = 0.84 \text{ sec/rotation}$$

$$\therefore \frac{1}{x} = \frac{1}{0.84} = 1.19 \text{ rotation/sec}$$

$$\therefore \omega_r = \frac{1}{x} \times 60 \text{ sec} = 1.19 \times 60 = 71.4 \text{ rotation/min}$$

Therefore, from equation (3.3.3),

$$T = \frac{P_R}{\omega_r} = \frac{54 \text{ watt}}{71.4 \text{ rpm}} = 0.756 \text{ N.m} \cong 7.709 \text{ kgf.cm}$$

$$0.756 \text{ N.m} = \sqrt{3} \times 5 \times 10.8 \times \text{Cos}(\varphi) \rightarrow \varphi = 89.536^\circ$$

So, power factor easily founded as:

$$\sqrt{3} \times \text{Cos}(\varphi) = 0.014 \tag{3.3.4}$$

Where power factor is defined as the ratio of active power to apparent power in the electrical power system and is a number between 0 and 1. Because of the result of the equation (3.3.4) is between 0 and 1, whole calculations provided and justified.

∴ MG996R type high-torque servo motor was selected after calculating the power, voltage, ampere, and torque values needed by the snake.

3.3.2. Mass and Volume Calculations

Mass and volume are one of the most crucial parameters for calculating the center of gravity of the multi-linked masses of the snake robot and the friction required to achieve effective serpentine motion. Before proceeding to the calculations on center of gravity and friction, the 3D printer filament to be used with respect to the mass and volume will be discussed in this section. Values for mass and volume was obtained from SolidWorks by Dassault Systèmes, a 3D modeling and simulation tool that was used widely in this project. The volume, mass, density, and surface area data of the robot are shown in table 9 and their calculation formulas provided and discussed as follows:

Table 9: Physical properties of 3D printed parts calculated in SolidWorks

Part Parameter s	Servo Segment	Nose Servo Mount	Tail Servo Mount	Nose Cap	Tail Cap	Servo Base Plate	Total
Density $(\frac{kg}{m^3})$	1250	1250	1250	1250	1250	1250	1250
Mass (gr)	49.06	41.59	32.47	36.94	36.75	2.36	715.73
Volume (mm^3)	39247.92	33272.89	32470.67	29554.39	29402.76	1889.43	579100.9 9
Surface Area (mm^2)	17446.75	13812.74	12787.22	17361.15	17133.41	3704.71	297465.2 9
Quantity	11	1	1	1	1	12	-

Excluding mechanical parts like bearings, servo motor arms, servo motors and other electronic components, leaving only the 3D printed shell of the snake robot, the shell properties were evaluated, and the amount of 3D printing resources required were calculated as follows with respect to the filament property table (x).

$$\text{Mass} = 715.73 \text{ gr} = 0.7 \text{ kilograms} \quad (3.3.5)$$

$$\text{Volume} = 579100.99 \text{ mm}^3 = 5.8 \times 10^{-4} \text{ m}^3 \quad (3.3.6)$$

$$\text{Surface Area} = 297465.29 \text{ mm}^2 = 0.3 \text{ m}^2$$

Table 10: 1 kg PLA+ Filament Properties

1 kg PLA+ Filament Properties	
Density ($\frac{kg}{m^3}$)	1250
Volume of unit mass ($\frac{m^3}{kg}$)	8×10^{-4}
1.75 mm-1 kg filament length on reel (meters)	330

From equation 3.3.5,

$X \text{ m}^3 \text{ filament need} = \text{Mass of snake} \times \text{Volume Unit Mass of 1 kg filament}$

$$= \frac{0.7 \text{ kg} \times 8 \times 10^{-4} \text{ m}^3}{1 \text{ kg}} = 5.6 \times 10^{-4} \text{ m}^3 \text{ filament required}$$

$\therefore 5.6 \times 10^{-4} \text{ m}^3$ or 0.7 kg filament needs to be printed to have a complete snake robot shell structure. The following table lists all the parts of the snake robot including non-printed parts to find the total mass of the snake robot. The mass of the wiring is assumed negligible.

Table 11: Mass of all integrated components

Components	Quantity	Mass (g)
3D-Printed parts	1	715.73
Servo Arms	12	1.39
Bearings	12	0.97
Servo Motor	12	31.73
Screws	48	1

Arduino Uno	1	25
Wi-Fi Camera	1	44.8
IR Sensor	1	5.06
Total Mass= 1247.67 grams = 1.25 kg		

3.3.3. Center of gravity

Center of gravity helps to find average position of any object and explains the motion of the object as it travels through translation of the center of gravity from place to place. The model of a multi-link mechanism is shown in the figures below.

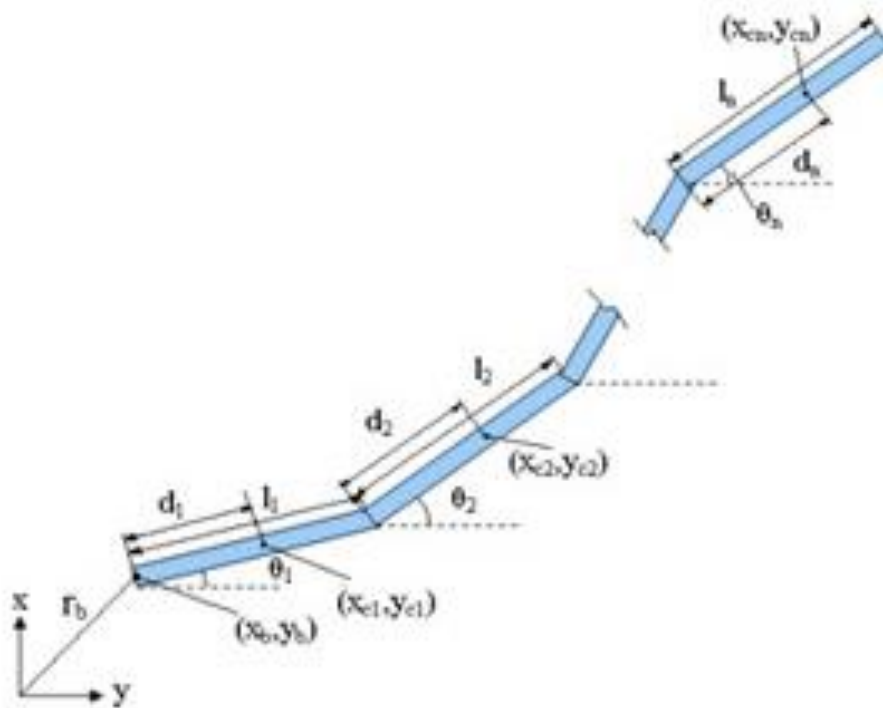

Figure 24: n-link snake robot

(“(PDF) Design, Construction and Dynamic Modeling of a Snake Robot,” n.d.)

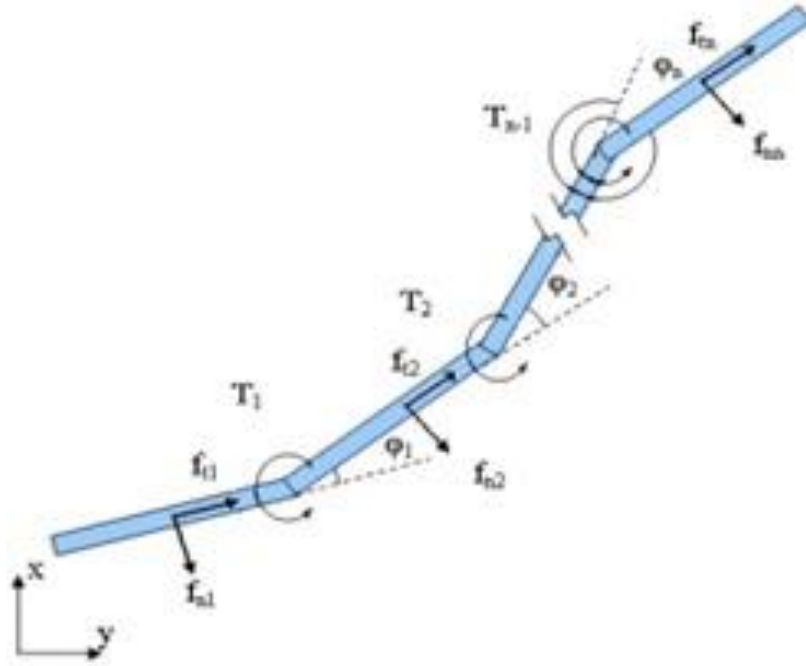

Figure 25: Free body diagram of n-link snake robot

(“N-Link Snake Robot Figure 2. Free Body Diagram of n-Link Snake Robot. | Download Scientific Diagram,” n.d.)

In first picture in figure 24, n links connected through n-1 joints was illustrated. In addition, each joint has uniformly distributed mass and equipped with a torque actuator which is servo motor.

Defining each variable on the figure 24:

$$x_{ci} = x_b + \sum_{j=1}^{i-1} l_j \cos \theta_j + d_i \cos \theta_i$$

$$= 188.21 + 47.5 \times \cos(0) + 11 + 23.75 \times \cos(0) = 426.96$$

$$y_{ci} = y_b + \sum_{j=1}^{i-1} l_j \sin \theta_j + d_i \sin \theta_i$$

$$= 232.6 + 113.44 \times \sin(0) + 11 \times 113.44 \times \cos(0) = 232.6$$

$$\therefore CG \text{ coordinates} = (x_{ci}, y_{ci}) = (426.96, 232.6)$$

3.4. Cost Analysis

All necessary components and their details are summarized in table 12 below.

Table 12: Bill of Materials

Bill of Materials							
Item #	Part #	Quantity	Name	Material	Manufacturer/Vendor	Price	Total Unit Price
1	1-3-1 1-3-2	12	Tower Pro MG996R 4.8 ~ 6.6V Servo Motor and connections	Various	Robolink Market Phone: +90 (850) 241 87 54 E-mail: <a href="mailto:info@robo
linkmarket.
com">info@robo linkmarket. com	\$74.16	\$6.18
2	1-0-1	1.75 mm length, 1000g	3D-Printer Filament	PLA+	3DJAKE Phone: 0800 55 66 40 515 E-mail: <a href="mailto:global@3d
jake.com">global@3d jake.com	\$11.97	\$11.97
3	1-6-1	12	608-2RS 8x22x7 Sealed Greased Miniature Ball Bearings	AISI 52100 Chrome Steel	BC TRADE Phone: (904) 651- 9331 E-mail: customerca	\$8.05	\$0.805

					re@bcprecision.com		
4	1-0-2	40	Phillips head screws 6-32 x 1/2"	Steel	Jet Fitting & Supply Corp, Phone: 92705-4118	\$6.98 (10 items)	\$1.745
5	1-0-3	8	Phillips head screws 6-32 x 1/4"	Stainless Steel	Homedepot.com Phone: 1-800-430-3376	\$1.86 (3 pack)	\$0.62
6	1-0-4	-Red and black (20 AWG 2 piece) -Standard (22 AWG 1 piece) 5 m each	Gauge wire	Silicone wire and Copper cables	Aliexpress,	\$5.94	\$5.94
7	1-0-5	20 pieces, 4 inch each	Zip Ties	Nylon	Outus (N/A contact info. Vendor is Amazon.com)	\$9.99 (1000 pack)	\$9.99 (1000 pack)
8	1-0-6	30	Male header pins (split into	Various	to be acquired	to be acquired	to be acquired

			10 lots of 3)		from local market*	from local market*	from local market*
9	1-0-7	1	Arduino UNO	Various	to be acquired from local market*	\$5.94	\$5.94
10	1-0-8	1	Electrolyti c Capacitor 1000uF 25V	Various	KEMET Corporatio n Phone: +1- 954-766- 2800	\$0.576	\$0.576
11	1-0-9	1	Adjustable Power Supply	Various	ATX Phone: 289-204- 7800	Already acquired	Already acquired
12	1-1-0	1	IR Remote Controller	Various	Arduino	\$1.78	\$1.78
13	1-1-0-1	1	TCRT5000 Infrared Sensor	Various	Robotistan Elektronik Ticaret AS, E-mail: info@robo tistan.com Phone: 0850 766 0 425	\$0.14	\$0.14

14	1-0-7-1	1	Arduino Camera Module	Various	INT-EL INTERNA TIONAL, E-mail: <a href="mailto:destek@dir
enc.net">destek@dir enc.net Phone: 0850 450 47 47	\$9.26	\$9.26
				Total component cost: \$136.22			

All the prices mentioned above are in USD (United States Dollars)

When calculating cost, average prices are assumed.

Table 13: Total cost prediction

Cost of components	\$136.22
Cost of shipping	\$60.50
3D printing	\$100
Tax	\$12.65
Total cost	\$309.37

The cost of the servo motors is the highest when compared to the cost of other electronic components. This is followed by the cost of the 3D printing filament which will be used to generate the structural components of the snake robot, comprising of the head and tail cap as well as the middle joints. Ball bearings, screws, wiring and zip-ties make up 24% of the overall components cost while the Arduino Uno microcontroller, camera module and other electronic parts form about 13% of the overall components cost as shown in the pie chart below.

The prices above are based on both local and global markets. Local market prices (in Turkish Lira) have been converted into USD; therefore, prices of certain products may fluctuate with respect to the current exchange rate.

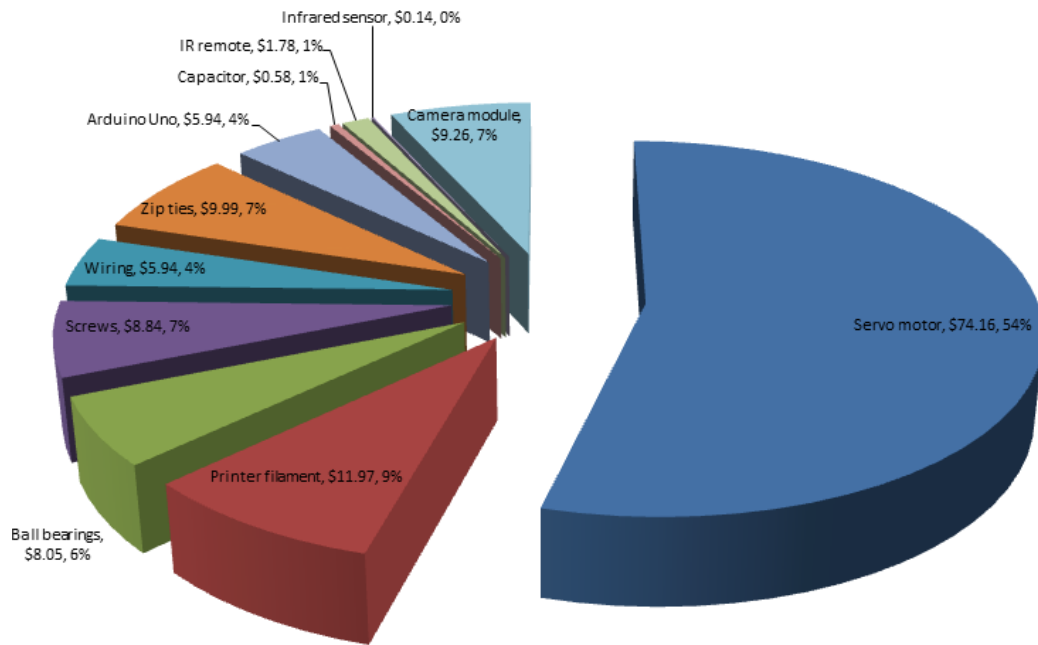

Figure 26: Pie chart showing percentage of each component cost out of total component cost

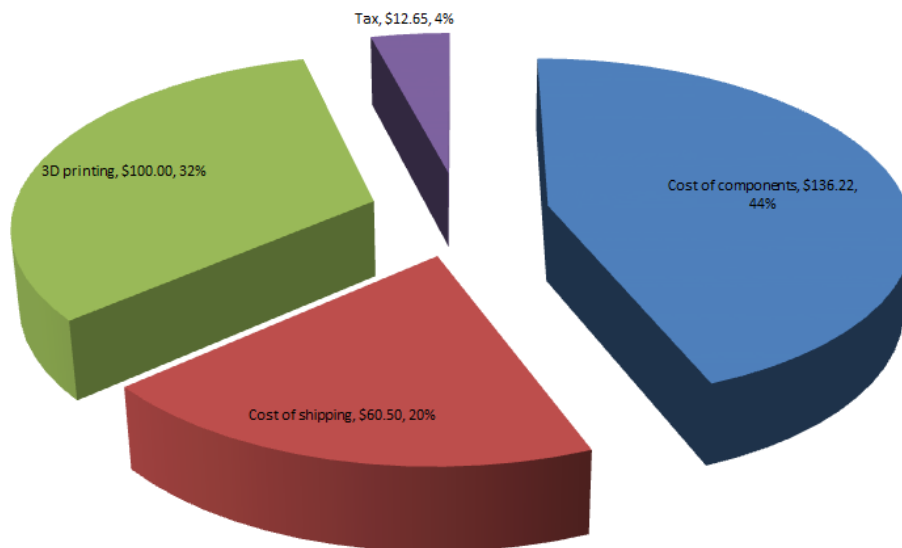

Figure 27: Pie chart showing percentage tax, 3D printing, shipping and components cost with respect to total cost.

3.5. Reliability analysis

In the following, the reliability analysis of the electronic and some mechanical parts will be described with the aid of reliability block diagram representations, fault-tree analysis, failure modes and effects analysis and other reliability tools.

3.5.1. System Hierarchy

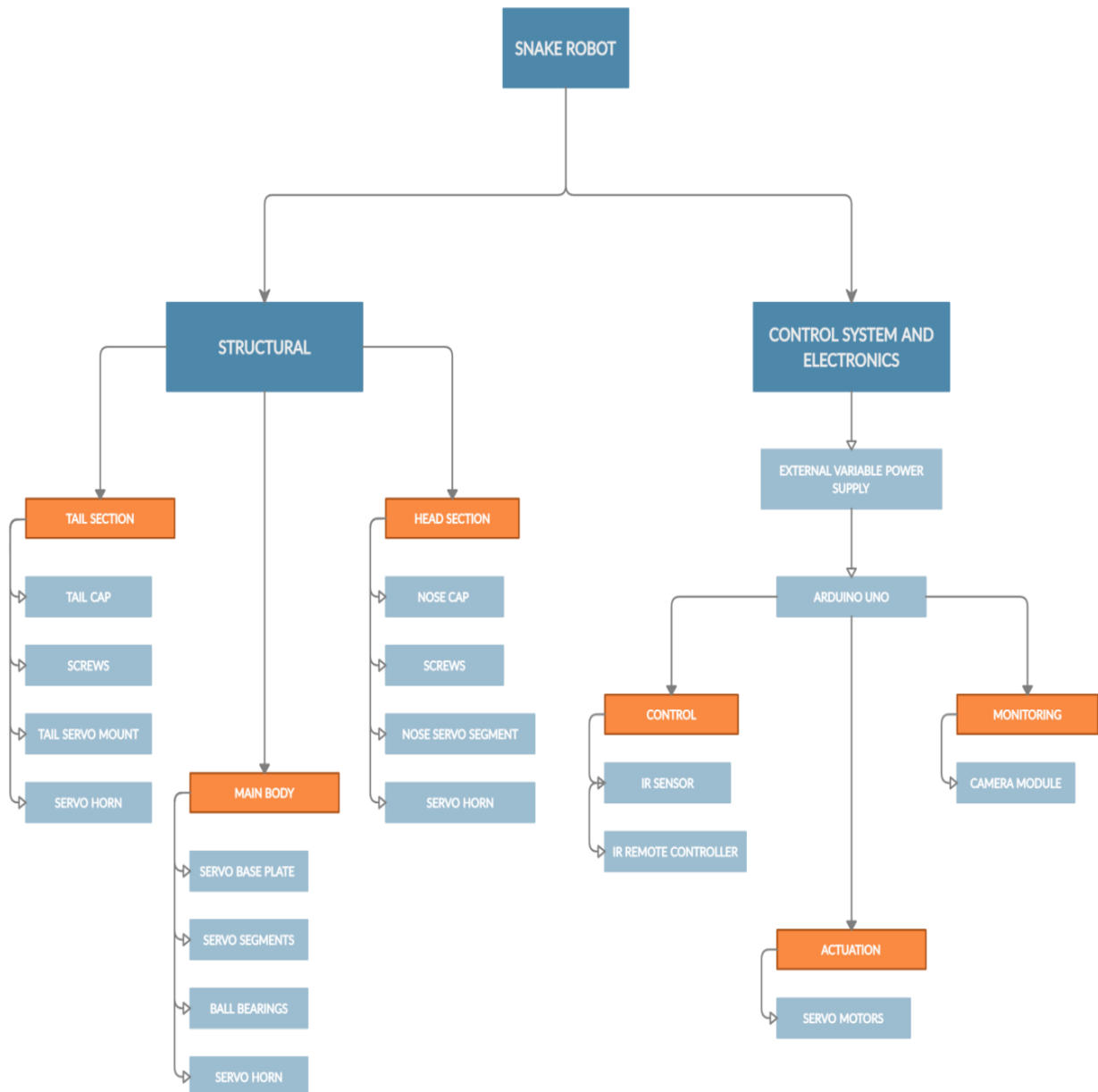

Figure 28: Snake robot system hierarchy

3.5.2. Product life cycle of the snake robot

With reference to (“ISO - ISO 14040:2006 - Environmental Management — Life Cycle Assessment — Principles and Framework,” n.d.) the “consecutive and interlinked stages of a product system, from raw material acquisition or generation from natural resources to final disposal.” is known as product life cycle. The life cycle analysis of a given product naturally consists of an upstream process, which involves the selection and extraction of the appropriate materials and components for the product, and a downstream process which defines the processes required for the proper disposal of the product at the end of its life. The upstream process of the snake robot involves acquiring the servo motors, designing of the servo casings’, controller selection and programming as well as the mechanical assembly of the entire robot and the downstream process will deal with the disposal of the 3D-printed parts, which will heavily depend on the type of material used for the printing, and disposal of electrical components like batteries that use electrolytes that can cause harm to humans as well as the natural surroundings. After the assembly of the snake robot, its operational efficiency will be tested with respect to a series of mechanical and electrical tests.

The purpose of the testing phase is to ensure that the snake robot operates within the specified limits and meets the design, performance, cost, manufacturability and reliability objectives set by the designers and constructors. If successful and the design team is confident that no further testing is required, then the product will be launched into its operation phase which will involve direct interaction with the customers and interested parties. This is known as the operation stage and the product is expected to perform at a relatively steady rate in terms of reliability and performance, assuming no external random factors like damage by dropping or misuse is considered, until it slowly declines towards its end of life. The product will be introduced to this operational phase via selected marketing and advertisement strategies targeting a specific category of customers and interested parties, as decided by the marketing

team. In the case of the snake robot, the marketing and advertisement is handled by our three-man engineering team.

The product life cycle of such a system or any given system can be easily visualized at a basic level with the aid of a bath-tub curve.

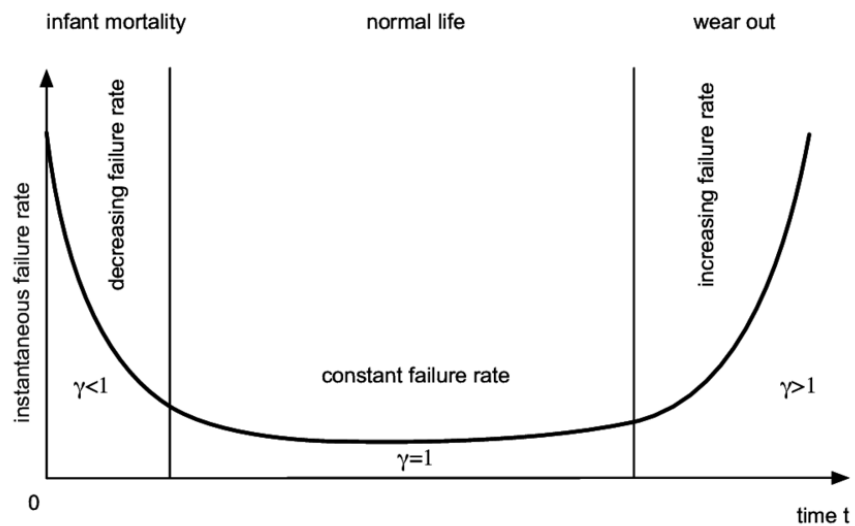

Figure 29: A bath-tub curve

(“Semantics of the Weibull Distribution (the Bathtub Curve) | Download Scientific Diagram,” n.d.)

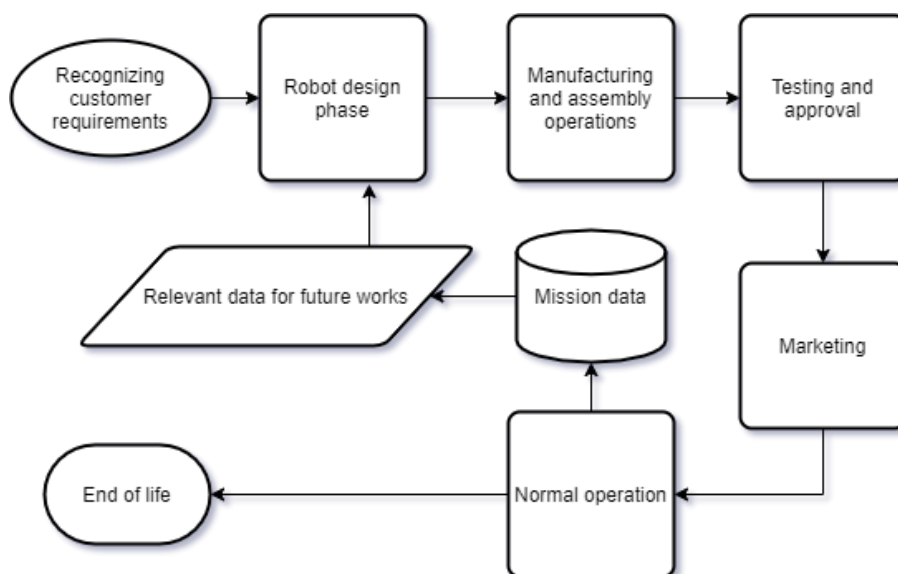

Figure 30: Life cycle of the snake robot

3.5.3. Quality Function Deployment (QFD)

This concept centers on the development of a given product with respect to the demands of the customer based on which the product will be deployed. This means the technical aspects of said product is translated from the requirements of the customers and will reflect these newly integrated characteristics in any given stage of product development. As an example, a customer who is willing to buy a robotic snake for probing missions will be concerned about its portability, one of many factors on the design side of the project, as well as the timing, planning and costing of the product being deployed. The technical response to this can be seen in the product itself, whether the final iteration of the robot features an internal power supply to allow for more portability but a compromise on mission time due to significantly more down time in recharging the power unit, or in contrast, an external power supply compromising portability to mission time or even the number of components used in the overall construction, to pave way for improved time of assembly, less overall cost of components and maybe even better reliability.

The aim of this model is to help engineers meet or (depending on the project itself) surpass the needs of the customers, which in return will yield a product boasting relatively higher quality as opposed to a product that is designed without any customer feedback. According to (Chan & Wu, n.d.), the primary functions of QFD include but is not limited to product development, quality control as well as customer requirements analysis. Furthermore, the authors mention that these QFD functions can be expanded to house product design and planning, decision-making within the technical divisions in the project teams, project management, timing as well as cost. In conclusion, there is no restrictions or limitations to the potential of QFD with respect to practical engineering scenarios.

3.5.4. Failure data of snake robot components

In the following section, three different failure datasets were composed, consisting of failure rates as well as MTBF and MTTF of both mechanical and electrical components from various sources. Exponential reliability of each part or group of parts have been calculated for reliability at 500 hours. The resultant reliability derived from these three datasets will be compared in Section 2 under a sensitivity analysis of the snake robot system. Some values of failure rates, the failure rates of 3D printed PLA+ components, have been assumed by the team since the project is still at the preliminary design phase, testing of parts are yet to be conducted and the field data is yet to be recorded. Most of the failure data obtained in the three models were with respect to MIL-HDBK-217 F as well as Bellcore/Telcordia and Naval Surface reliability prediction models. Other failure rates have been obtained from various research papers in the field of robotics or specifically, the works related to individual electronic components. The failure data used in some of the research works used as a reference also used reliability standards from military handbooks but may not be directly mentioned. An expanded discussion of the sources of the failure data will be included in this section. The tables below show failure datasets A, B and C for the electronic and mechanical components of the snake robot as well as a summary of the sources from which they were obtained.

3.5.4.1. Sources for failure dataset A

The failure data for the power supply unit and the Arduino Uno was extracted from the works of (Rosendo et al., 2019), a paper based on a possible transition from a conventional data center infrastructure to a next-generation virtual data center. Their aim was to analyze and prove the benefits of the migration with respect to availability as compared to a conventional data center architecture. The reliability of the IR sensor, servo motors as well as the ball bearings were obtained with the aid of the reliability analytics toolkit from (“Reliability

Analytics Toolkit,” n.d.). The failure per million hours of a servo motor was found first with the calculations mentioned in the MIL-HDBK-217 F (Notice 2) then the reliability was determined using active redundancy without repair in the reliability analytics toolkit. Furthermore, the L10 life of the ball bearing was obtained from NSCW-11, then converted from L10 to MTBF using the reliability analytics toolkit online. The failure rate of the ball bearing was then calculated from the MTBF. The failure data for the camera module was obtained from the works of (Ji et al., 2018), which is based on the reliability characterization of CMOS image sensors on a mobile platform. Furthermore, in their works, the optimization of the design as well as manufacturing process of CIS products are discussed. The failure rate of the 3D printed PLA+ components, composed of the nose cap, nose servo mount, servo segment, servo base plate, tail servo mount and tail cap, have been assumed to have a failure per million hours of 200 since there is no test data available.

Table 14: Failure dataset A

Sources: (Rosendo et al., 2019), (“Reliability Analytics Toolkit,” n.d.), MIL-HDBK-217 F (Notice 2), NSCW-11, (Ji et al., 2018)

Part number	Part name	Number of parts	Failure rate/mil.hours	Failure rate/ hour	MTBF (hours)	MTTF (hours)	Reliability (at 500 hours)
1-0-9	External power supply	1	3.859	0.000003859	259134.491	X	0.9980724
1-0-7	Arduino Uno	1	3.425	0.000003425	X	291970.803	0.9982890
1-1-0-7	IR sensor	1	0.031	0.000000031	X	32258064.516	0.9999845
1-0-7-1	Camera module	1	11.415	0.000011415	X	87604.030	0.9943088
1-3-1	Servo motors	12	37.585	0.000037585	26606.359	X	0.9813830
1-6-1	Ball bearings	12	2.69	0.00000269	371747.212	X	0.9986559
1-1	Nose cap	1	200	0.0002	X	5000.000	0.9048374
1-2	Nose servo mount	1	200	0.0002	X	5000.000	0.9048374
1-6	Servo segment	11	200	0.0002	X	5000.000	0.9048374
1-3	Servo base plate	12	200	0.0002	X	5000.000	0.9048374
1-7	Tail servo mount	1	200	0.0002	X	5000.000	0.9048374
1-8	Tail cap	1	200	0.0002	X	5000.000	0.9048374

3.5.4.2. Sources for failure dataset B

The power supply failure rate for this dataset was obtained from (“Embedded Computer Architecture 5 SAI 0 Micro Processor,” n.d.), an overview of performance and reliability of microprocessor architectures. Specifically, the failure data was noted from the MTTF of a

power supply unit within a disk subsystem. Arduino Uno failure rate was determined with respect to the works of (Shrikhande, Patil, Ganesh, Biswas, & Patil, 2010), which is based on the reliability analysis of safety critical and safety related systems of Indian nuclear plants. The reliability prediction model used in this paper is the MIL-HDBK-217F and the failure rate of the CPU-board in failure per million hours is noted in the hardware module failure rates section. The failure data for the IR sensor was found from (“Lees’ Loss Prevention in the Process Industries: Hazard Identification ... - Frank Lees - Google Books,” n.d.) from sensors relating to fire protection systems. This failure rate is based on a combination of both infrared and ultraviolet sensors in the mentioned system. The failure data for the camera module was obtained from a paper by (Zhou, Ma, Yu, Li, & Hang, 2020), based on the analysis of reliable wafer level chip scale packaging (WLCSP) for CIS integrated within automotive systems. The ball bearing fatigue life L10, as done previously, was calculated from NSCW-11 and later converted to MTBF via the reliability analytics toolkit online whereas the failure data for individual servo motors was found from (“Reliability Engineering Handbook - Dimitri Kececioglu - Google Books,” n.d.). This failure rate was then computed with respect to active redundancy without repair with the reliability analytics toolkit to find the overall actuation reliability. The failure rate of the 3D printed PLA+ components have been assumed to have a failure per million hours of 300 since there is no test data available.

Table 15: Failure dataset B

Sources: (“Embedded Computer Architecture 5 SAI 0 Micro Processor,” n.d.), (Shrikhande et al., 2010), (“Lees’ Loss Prevention in the Process Industries: Hazard Identification ... - Frank Lees - Google Books,” n.d.), (Zhou et al., 2020), MIL-HDBK-217F, NSCW-11, (“Reliability Engineering Handbook - Dimitri Kececioglu - Google Books,” n.d.)

Part number	Part name	Number of parts	Failure rate/mil.hours	Failure rate/ hour	MTBF (hours)	MTTF (hours)	Reliability (at 500 hours)
1-0-9	External power supply	1	5	0.000005	200000.000	X	0.9975031
1-0-7	Arduino Uno	1	7.29	0.00000729	X	137174.211	0.9963616
1-1-0-7	IR sensor	1	7.36	0.00000736	X	135869.565	0.9963268
1-0-7-1	Camera module	1	93.212	0.000093212	X	10728.232	0.9544634
1-3-1	Servo motors	12	666.6	0.0006666	1500.150	X	0.7165552
1-6-1	Ball bearings	12	1.1	0.0000011	909090.909	X	0.9994502
1-1	Nose cap	1	300	0.0003	X	3333.333	0.8607080
1-2	Nose servo mount	1	300	0.0003	X	3333.333	0.8607080
1-6	Servo segment	11	300	0.0003	X	3333.333	0.8607080
1-3	Servo base plate	12	300	0.0003	X	3333.333	0.8607080
1-7	Tail servo mount	1	300	0.0003	X	3333.333	0.8607080
1-8	Tail cap	1	300	0.0003	X	3333.333	0.8607080

3.5.4.3. Sources for failure dataset C

The MTBF, which was later converted to failure rate, for the power unit in this case was found from the component datasheet of a similar power unit manufactured by Camtec Power Suppliers, under the model HSD10001. This is a 1000W power supply featuring an ambient operation temperature between -25 to 70 degrees Celsius with two phase operations. The failure data for the Arduino Uno itself was unavailable but the data for the Arduino Nano was found from the proceedings in (“Smart Innovations in Communication and Computational Sciences: Proceedings ... - Google Books,” n.d.), and therefore was included in the reliability calculations under the assumption that the reliability of most of the Arduino board models are within a small range of themselves. Revisiting the works of (“Lees’ Loss Prevention in the Process Industries: Hazard Identification ... - Frank Lees - Google Books,” n.d.), the failure rate of a standalone IR sensor was found, unlike the combined system discussed in dataset B. Failure data for the camera module was found in the works of (“Safe, Autonomous and Intelligent Vehicles - Google Books,” n.d.). The failure rate of the CMOS sensor was taken as the worst case in the

first stage of temperature variation, according to the text, which was 8.97 percent. Servo motor failure data was obtained from the works of (Sarson-Lawrence, Sabatini, Clothier, & Gardi, 2014), where they discuss the reliability factors encompassing off-the-shelf components integrated within low-cost unmanned Aircraft. They further elaborate on the methods and ways in which to understand the reliability of mini-UA servo motors with respect to the experimental values for time-to-failure within a monitored set of test runs. This failure data was input in the reliability analytics toolkit for active redundancy without repair to obtain the overall reliability of the actuation system of the snake robot. The ball bearing fatigue life L10, was calculated from NSCW-11 and later converted to MTBF via the reliability analytics toolkit online. The failure rate of the 3D printed PLA+ components have been assumed to have a failure per million hours of 400 since there is no test data available.

Table 16: Failure dataset C

Sources: CAMTEC Power Suppliers, ("Smart Innovations in Communication and Computational Sciences: Proceedings ... - Google Books," n.d.), ("Lees' Loss Prevention in the Process Industries: Hazard Identification ... - Frank Lees - Google Books," n.d.), ("Safe, Autonomous and Intelligent Vehicles - Google Books," n.d.), (Sarson-Lawrence et al., 2014), NSCW-11, ("Reliability Analytics Toolkit," n.d.)

Part number	Part name	Number of parts	Failure rate/mil.hours	Failure rate/ hour	MTBF (hours)	MTTF (hours)	Reliability (at 500 hours)
1-0-9	External power supply	1	2	0.000002	500000.000	X	0.9980020
1-0-7	Arduino Uno	1	0.18	0.00000018	X	5555555.556	0.9998200
1-1-0-7	IR sensor	1	11.94	0.00001194	X	83752.094	0.9881310
1-0-7-1	Camera module	1	93.981	0.000093981	X	10640.449	0.9103001
1-3-1	Servo motors	12	83.868	0.000083868	11923.499	X	0.9195526
1-6-1	Ball bearings	12	0.82	0.00000082	1219512.195	X	0.9991803
1-1	Nose cap	1	400	0.0004	X	2500.000	0.6703200
1-2	Nose servo mount	1	400	0.0004	X	2500.000	0.6703200
1-6	Servo segment	11	400	0.0004	X	2500.000	0.6703200
1-3	Servo base plate	12	400	0.0004	X	2500.000	0.6703200
1-7	Tail servo mount	1	400	0.0004	X	2500.000	0.6703200
1-8	Tail cap	1	400	0.0004	X	2500.000	0.6703200

3.5.5. Reliability block diagrams of snake robot system and subsystem

As described in the system hierarchy, the snake robot system is subdivided into two main categories, structural and electronics respectively. These two categories are assumed to be in series with each other as shown in the reliability block diagram below, which suggests that if either of the system fails, the snake robot will not operate properly. In real operating environments, a small defect in either subsystem may or may not directly affect the performance of the snake robot. Thus, the subsystems are assumed to be in series in order to understand the reliability in the worst case possible.



Figure 31: RBD of structural and electrical subsystem

The structural subsystem and the mechanical components that support it are highlighted in the reliability block diagrams in orange whereas the control system and electronics have been highlighted in blue. The table below shows the overall reliability of the snake robot when the individual reliabilities of the structural and electronics subsystems are computed in series with respect to the failure datasets mentioned earlier.

Table 11: Overall snake robot system reliability

Snake robot reliability	
Failure dataset	Reliability
A	6.429345%
B	1.172149%
C	0.001667%

The figure below is an expanded description of the structural subsystem comprising of the head, main body and tail section. The head section is composed of the nose cap which is connected to the nose servo mount via screws. A 608-2RS Sealed Greased Miniature Ball Bearing relates to the nose servo mount. The main body is made up of 11 servo segments in series with each segment connected to a servo base plate as well as a 608-2RS ball bearing. There are a total of 11 ball bearings and 11 servo base plates integrated in the main body. Lastly, the tail section of the snake robot consists of a tail servo mount with base plate connected to a tail cap, a similar configuration to the head segment apart from the base plate.

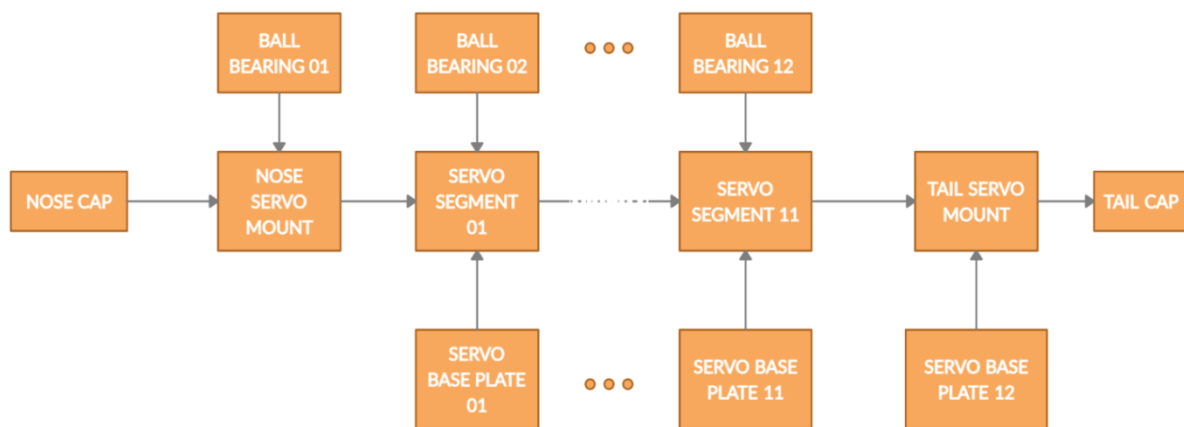

Figure 32: RBD of expanded structural subsystem

The table below summarizes the resultant reliability in percentage of the structural subsystem of the snake robot as computed on Microsoft Excel, with respect to the three failure datasets composed in the earlier section.

Table 12: Structural subsystem reliability with respect to failure datasets.

Structural subsystem reliability	
Failure dataset	Resultant system reliability
A	6.612952%
B	1.730777%
C	0.002020%

The control system and electronics is composed of control, actuation and monitoring as described in the system hierarchy. The figure below shows the expanded components in the control and monitoring system. The control branch is basically the IR sensor and remote controller working via the Arduino Uno and the monitoring branch involves the camera module, which is also connected to the board, since both branches are linked via the Arduino. The variable supply or power unit is connected in series to the Arduino Uno. The actuation branch is not fully described in the figure below because it is a larger network of servo motors in parallel and will therefore be represented with dedicated block diagrams later. The resultant reliability of the power unit, Arduino Uno and the 2 highlighted branches will be in series with the resultant reliability of the actuation branch.

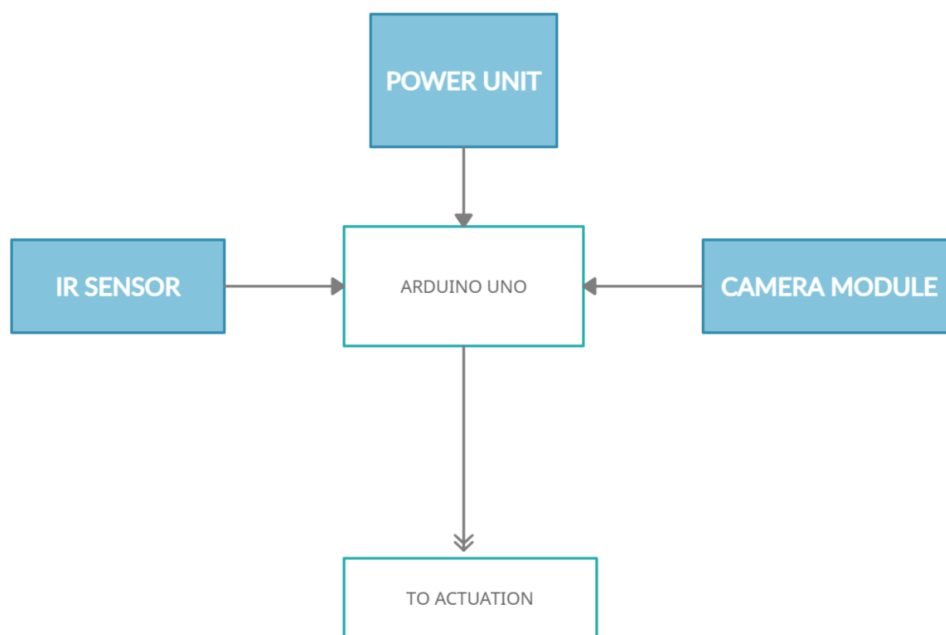

Figure 33: RBD of expanded electrical subsystem

The figure below is a further expansion of the actuation system within the electronics subsystem, comprised of 12 MG996R High Torque Metal Gear Dual Ball Bearing Servo connected in a parallel configuration. The resultant reliability of the servo system described, excluding the Arduino Uno, will be combined in series with the resultant of the power unit, Arduino Uno, IR sensor and camera module described in the previous figure.

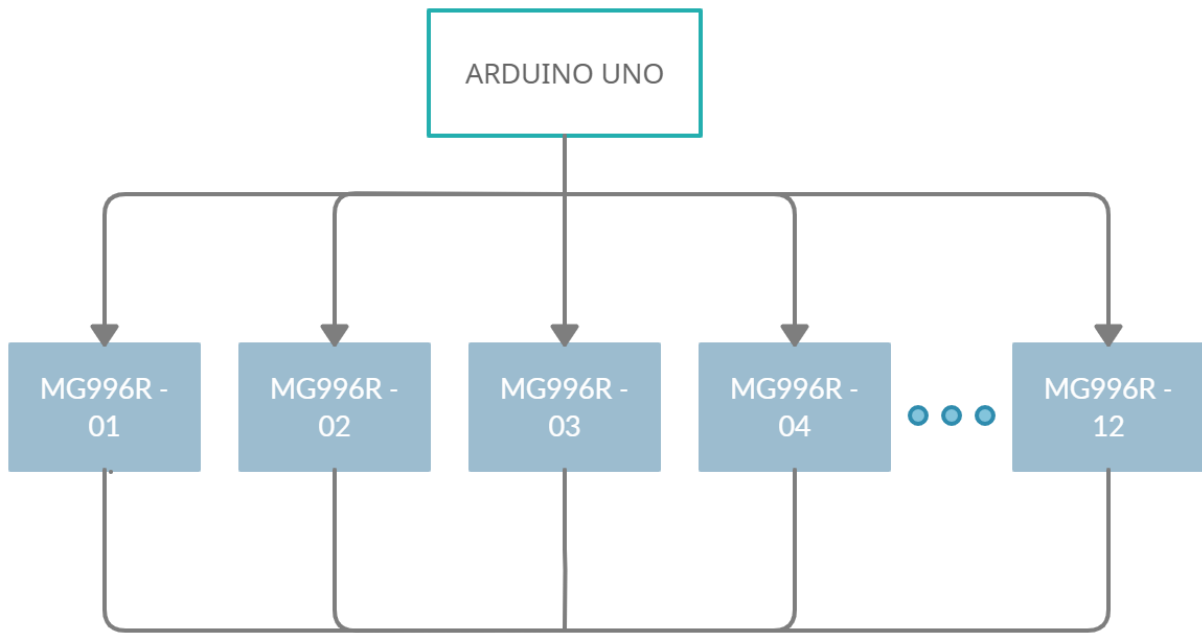

Figure 34: RBD of expanded actuation system within the electrical subsystem

The table below summaries the control systems and electronics reliability of the snake robot. It includes the reliability of the actuation system shown in figure 13 as well as the combined reliability of the power unit, Arduino Uno, IR sensor and camera module. Furthermore, the resultant reliability of the divided electronics subsystem RBD is computed in series relative to each other and recorded in the table.

Table 13: Control systems and electronics reliability.

Control systems and electronics reliability			
Failure dataset	Actuation reliability	PSU, control, and monitoring reliability	Resultant system reliability
A	98.138298%	99.067872%	97.223523%
B	71.655520%	94.513170%	67.723903%
C	91.955263%	89.753694%	82.533245%

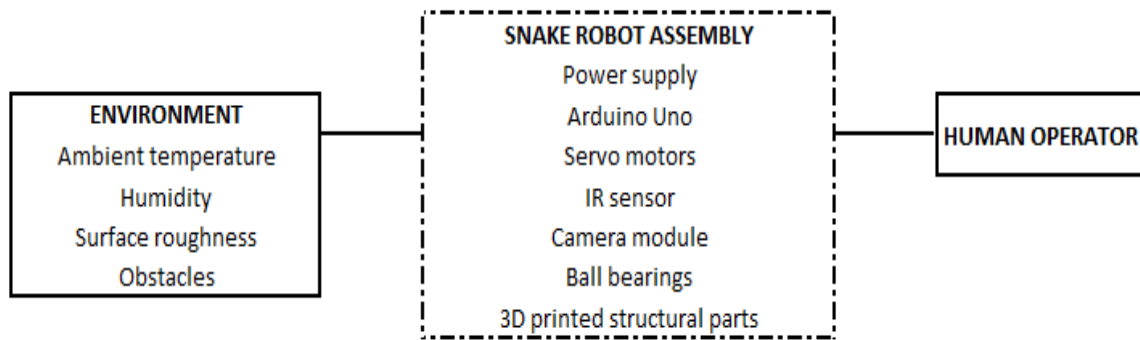

Figure 35: Boundary diagram of snake robot assembly

The boundary diagram is used to describe how the snake robot assembly interacts with its surroundings. This could be the environment, human operator or even other systems. Since the snake robot is a system on its own, the boundary diagram shown in figure 35 only describes environmental and human interaction. Factors like the ambient temperature of the room where the snake robot is operated, the humidity, the surface roughness as well as neighboring obstacles interact with the system whereas human interaction occurs during operation and maintenance.

3.5.6. Fault Tree Analysis (FTA)

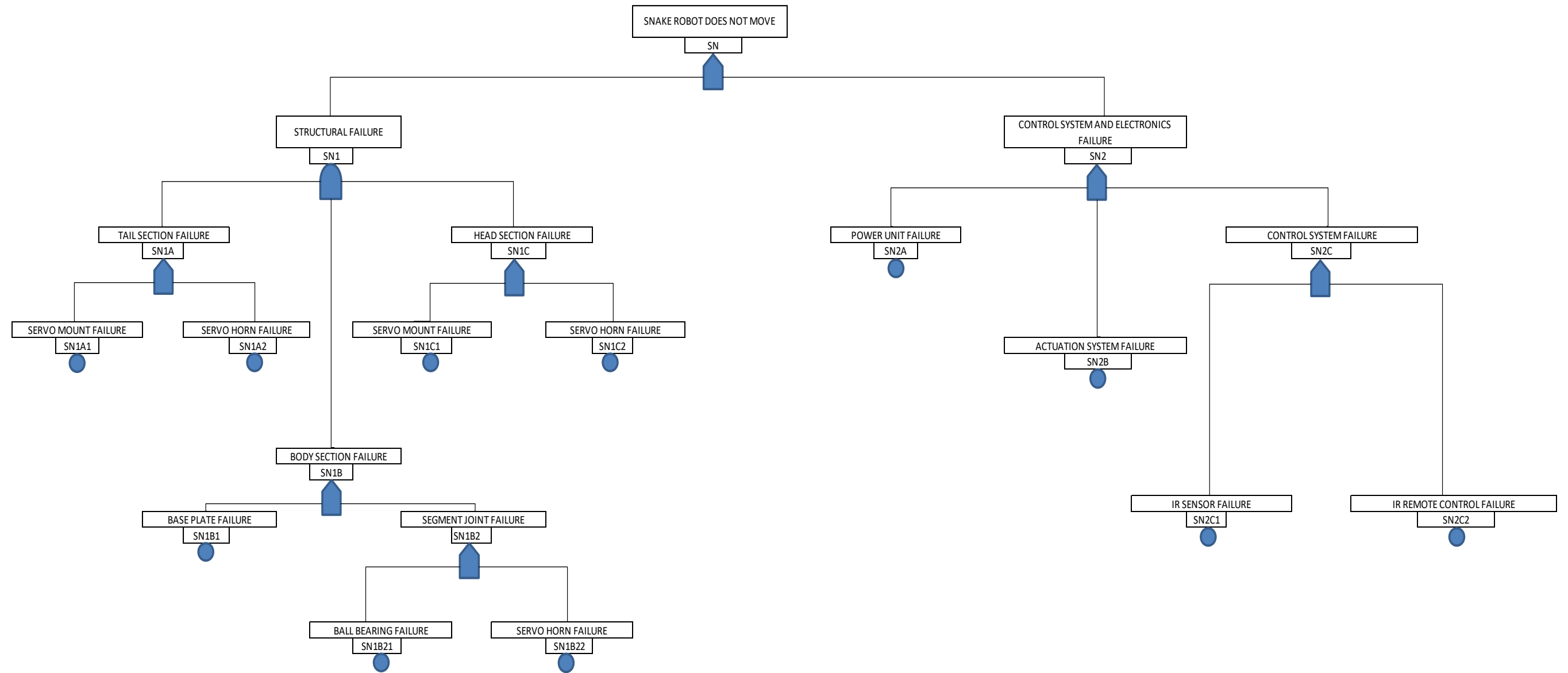

Figure 36: Fault Tree Analysis of snake robot

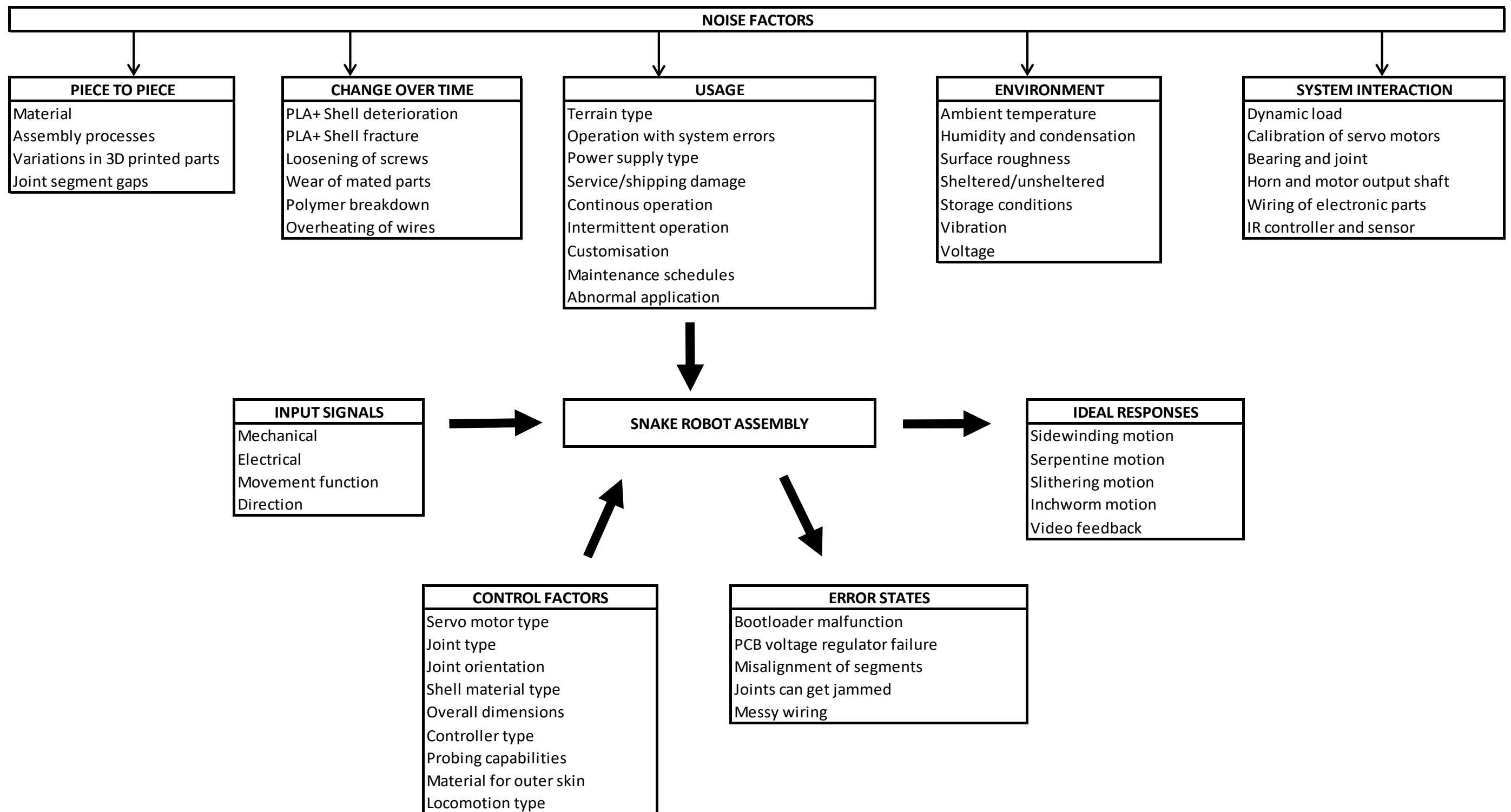

Figure 37: P-diagram of snake robot

3.5.7. Hazard and operability study (HAZOP)

NO	GUIDE WORD	ELEMENT	DEVIATION	POSSIBLE CAUSES	CONSEQUENCES	SAFEGUARDS	COMMENTS	ACTIONS REQUIRED	ACTIONS ASSIGNED TO
1	NO	Power supply unit operation	No power is supplied to the electrical components of the robot	Power supply is not properly connected. Power supply is not switched on. PCB and wiring inside the power unit is damaged. Power unit is completely depleted.	Snake robot is inoperable	Check for faults and maintain power supply unit more frequently	Revise DFMEA and update various types of failure modes of power supply unit	No actions	SHAH MOHAMMED ISFAR
2	LESS	Power supply unit operation	Less power than the minimum power rating of the electronic components is supplied	Power supply is not properly connected. PCB and wiring inside the power unit is damaged. Power supply unit has very low charge.	Snake robot is inoperable as some of the components will not work i.e. servo motors will not work but the sensors will depending on the power supplied. '	Check for faults and maintain power supply unit more frequently. Check the normal operating conditions of the components and use the power unit accordingly.	Revise DFMEA and update various types of failure modes of power supply unit	No actions	SHAH MOHAMMED ISFAR
3	MORE	Power supply unit operation	More power than the maximum power rating of electronic components is supplied	Fault in the internal parts of the power supply unit that causes power surge. Not checking the normal operating conditions of the snake robot. Lightning strike on the power unit when it is connected to the snake robot.	Electronic components are burned and damaged. Snake robot is inoperable. Operator is prone to electrocution if the power unit is not handled properly.	Make sure to operate the power unit in an environment which is not prone to lightning stikes. Check the normal operating conditions of the components and use the power unit accordingly.	Revise DFMEA and update various types of failure modes of power supply unit	No actions	SHAH MOHAMMED ISFAR
4	OTHER THAN	Normal operation environment fo snake robot	If robot is operated in any other environment other than the specified one, snake robot may malfunction and take damage	Operating the snake robot in an extremely wet environment, near water bodies than can enter the system and cause a short as well as extreme heat and humidity containing environments	Snake robot PLA+ shell may deteriorate at an accelerated rate. Permanent damage can be caused to electronic parts due to humidity, jerking forces as well as vibration	Design a safety box for tehe snake robot main control unit and sensors. Design a protective skin for the snake robot to shield from frictional damage and wet conditions.	Revise DFMEA and update various types of failure modes of snake robot PLA+ parts	No actions	SHAH MOHAMMED ISFAR
5	MORE	Servo motor speed	If more speed of operation is demanded from the servo motors, the mechanical and electrical components will wear out faster.	Due to higher servo motor speeds and the complexity of the locomotion modes, the snake robot will be subjected to higher levels of shock and vibration. Faster speeds imply more frictional contact at any given time for the 3D printed shell as well as joints.	Snake robot PLA+ shell will deteriorate at an accelerated rate. Damage can be caused to electronic parts due to higher rate of cyclic loading.	Do not operate snake robot at extremely high speeds for long durations. Allow for cool down time of servo motors and electrical components.	Revise DFMEA and update various types of failure modes servo motors	No actions	SHAH MOHAMMED ISFAR

Table 17: Hazard and operability study of snake robot

3.5.8. System Design FMEA (Failure Modes and Effects Analysis)

Part number	Item Function	Potential Failure Mode	Potential Effect(s) of Failure	Sev	Potential Causes(s)/Mechanism(s) of Failure	Occur	Current control		Dete	RPN	Recommended Action(s)	Responsibility and Target Completion Date	Action Results				
							Prevention	Detection					Actions Taken	Sev	Occ	Det	RPN
1-0-7	Arduino Uno - Controlling the servo motors and other electronic components. Processing of inputs given by the user and translating them into the desired output.	No function	Snake robot does not move. No control over electronic components	9	Power supply depleted/not turned on. Fault in header pins or wiring. Vibration and shock causing damage to PCB.	8	Rewiring of the system and using heat shrink tubes to hold and protect pins and connections as well as exposed wires.	Robot will not respond to IR signals from remote controller.	5	360	Reorganise the wiring of the system. Use zip ties to hold wires together in place. Replace defective wires that show signs of corrosion or burns.	Muratcan Yuce - 25/07/21	No actions taken	9	8	5	360
		Short circuiting	Snake robot does not move. No control over electronic components	10	Voltage regulator failure due to power overload. Exposure to water bodies, excess humidity or condensation.	7	Adhere to normal operating conditions of snake robot and its components. Controlling the current density with care, especially in the design phase.	Burnt circuit. Burnt smell of wiring, fumes or overheating of the system	7	490	Do not supply excessive power to the system. Maintain the normal operating conditions of the components as much as possible. Define a safe voltage range to operate the robot. Consider the installation of a capacitor. Design a safety box for the Arduino Uno to protect from external environmental factors.	Muratcan Yuce - 25/07/21	No actions taken	10	7	7	490
		Software issues	Snake robot does not move. No control over electronic components	1	Issues faced during bootloader burning procedures. Code cannot be uploaded into the Arduino Uno.	8	Revise procedures for bootloader burning and check for errors in the coding. Adhere to the rules and regulations as mentioned on the Arduino website.	Software error messages when attempting to upload code into the Arduino.	2	16	Revise procedures for bootloader burning and check for errors in the coding. Adhere to the rules and regulations as mentioned on the Arduino website.	Abdulrahman Saber Ali - 25/07/21	No actions taken	1	8	2	16
1-3-1	Servo motors - Connected to the snake segments via servo horn and ball bearing. Shock proof double bearing. Operating voltage between 4.8V - 7.2V. Stall current 2.5A (6V). 0-55 degrees Celsius temperature range of motors and 55 degrees Celsius considered ambient temperature.	Broken servo horn	Servo output shaft rotates but no transmission to the joint due to arm failure. Snake robot does not move efficiently. Friction between mated parts	6	Fracture of servo horn due to cyclic loading and terrain conditions. Fatigue failure of servo horns due to heat, humidity and other environmental conditions.	6	Check servo horns for signs of cracks. Make sure servo horns are mounted properly is fit well on the servo output shaft.	Servo malfunction. Snake robot will not move efficiently. Locomotion is compromised. Excessive vibration due to lack of motion in affected segment(s).	1	36	Introduce metallic servo horns as opposed to plastic, due to higher resistance to external factors. Coat servo horns or install protective cap. Use 4 spoke servo horns instead of 2 spokes for better support on segment.	Shah Mohammed Isfar - 15/05/21	4 spoke plastic servo horns were introduced for better support.	6	6	1	36
		Bearing failure	Noisy motors, excessive heat build up, motor seized. Segments of the snake robot may not move properly.	10	Excessive cyclic loading, gear or shaft misalignment, frequent starts and stops, improper lubrication, contaminations from foreign particles, high temperature due to power overloading. Worn bearings, spalling or creeping.	3	Adhere to normal operating conditions of snake robot and its components.	Not likely to be detected. Affects the internal parts of the servo motor. Noisy motors.	10	300	Replace servo motors with worn bearings and spalling issues.	Shah Mohammed Isfar - 30/06/21	No actions taken	10	3	10	300
		Cracked motor housing	Leakage of dust and foreign particles inside the motor. Short or seize of motor that makes the snake robot inoperable.	7	Housing material fatigue, external vibrations and shock to the motor. Contamination from environmental factors. 3D printed PLA+ servo base plate fractured due to high temperatures, friction, vibration and shock.	7	Check motor housing for cracks. Avoid heavy use in rough environments, avoid dropping the snake robot from a height. Keep snake robot in a stable environment.	Servo malfunction. Snake robot will not move efficiently. Locomotion is compromised. Excessive vibration due to lack of motion in affected segment(s). Cannot be easily detected as sections of the servo motor will be covered by the 3D printed servo housing.	3	147	Design a servo mount segment to protect servo motors from external shock and forces that may cause damage. Seal cracked motor housing with adhesive or replace servo motor if there is severe crack propagation.	Shah Mohammed Isfar - 30/06/21	No actions taken	7	7	3	147
1-0-9	Power supply - The KXN-3020D Adjustable Power Supply will be used to provide electric power to the snake robot	PCB cracking	Snake robot does not move. No control over electronic components. Power unit is inoperable. Damage to surrounding components due to possible use with failed parts.	8	Power supply unit subjected to shock during shipping/transportations. Mishandling of device. Environmental factors like humidity and condensation or overheating of portions of the circuit which propagates certain PCB faults.	6	Handle the device carefully as per manufacturers instructions. Store at optimal room temperature free from dirt,sand or other foreign particles.	Not likely to be detected. Affects the internal parts of the power unit Only during maintenance.	8	384	Replace power supply unit. Store at optimal room temperature free from dirt,sand or other foreign particles. Run proper maintenance on the power supply unit with a specialist. Allow adequate ventilation to device during operation. Increase frequency of maintenance especially after heavy usage.	Muratcan Yuce - 05/08/21	No actions taken	8	6	8	384
		Fan failure/ Active cooling system failure	Overheating of power unit during operation. Can cause the power unit to malfunction and internal parts damage due to excessive heat generation. May affect overall performance of power unit that will in turn affect the robot.	4	Fan quality is low. This probably because of counterfeit fans introduced into the supply chain in the industry. Fans decrease the reliability of power unit as it's a major source of failure. Moisture ingress occurs during maintenance of parts when disinfecting solutions enter fan ports.	8	Run proper maintenance on the power supply unit with a specialist. Check fans and clean them after long use. Replace defective fans.	Noise from power unit. Over heating of the system.	5	160	Try to replace the current power supply unit with a fan-less power unit with passive cooling system. This has an advantage since it can be sealed to further protect the internal components from environmental factors like dirt and humidity.	Muratcan Yuce - 05/08/21	No actions taken	4	8	5	160
		Propagating PCB fault - Resistive heating	Overheating of parts of the power unit may heavily impact its operation. Damaged power components may deliver excess power to snake robot that will destroy the electrical components.	9	Conducting materials with elevated resistance. Insulating materials with diminished resistance. (Resistive heating). Overpowering the device can cause the resistive components to improperly dissipate heat.	7	Store at optimal room temperature free from dirt,sand or other foreign particles. Run proper maintenance on the power supply unit with a specialist. Allow adequate ventilation to device during operation. Avoid poor electrical connections.	Not likely to be detected. Affects the internal parts of the power unit Only during maintenance. Localised charring around the resistive components that failed. Discolouration of some internal parts. Surrounding circuit components may also be pyrolyzed.	8	504	Store at optimal room temperature free from dirt,sand or other foreign particles. Run proper maintenance on the power supply unit with a specialist. Allow adequate ventilation to device during operation. Increase frequency of maintenance especially after heavy usage. Replace power supply unit. Remove failed components.	Shah Mohammed Isfar - 05/08/21	No actions taken	9	7	8	504

Table 18: Snake robot system DFMEA

Table 19: Snake robot system DFMEA (continued)

1-1-0-1	IR sensor - Includes a daylight blocking filter and an emitter wavelength of 950 nm. For remote operation and control of snake robot.	Calibration	Snake robot may not respond efficiently to the remote control signals. Unintended response when a certain button is pressed on the remote control.	1	Controller bindings have not been specified or coded into the system. Controller has been changed or replaced with a different one.	3	Check initial calibration.	Can be detected via faults in snake robot movement or computer interface.	1	3	Can be detected via faults in snake robot movement or computer interface.	Abdulrahman Saber Ali - 25/07/21	No actions taken	1	3	1	3
		Electromagnetic interference	Snake robot may not respond efficiently to the remote control signals. Unintended response when a certain button is pressed on the remote control.	2	Electromagnetic radiation from external sources can be a possible cause of disturbance or obstruction to the normal performance of the sensor.	4	Operating snake robot away from strong sources of electromagnetic interference, Keeping other types of IR remote controllers away from the operation environment of the snake robot.	Can be detected via faults in snake robot movement or computer interface.	4	32	Introduce sensor or control device shielding.	Abdulrahman Saber Ali - 25/07/21	No actions taken	2	4	4	32
		Receiver failure	Snake robot will not respond to the remote control signals. Snake robot is inoperable.	7	Shock and vibration due to intense use of the robot in rough environments. Corrosion of parts due to humidity and condensation from the environment. Mishandling during device shipping or transport.	4	Protect sensor from external impacts by proper placement inside the robot segment.	Can be detected immediately if the snake robot does to respond to remote commands.	3	84	Replace with new sensor.	Abdulrahman Saber Ali - 25/07/21	No actions taken	7	4	3	84
1-0-7-1	Camera module - OV7670 type camera module has been used and assembled in head of the snake for monitoring the environment. Features a low voltage CMOS sensor. Single-chip VGA camera and image processor. 1.7 V to 3 V power supply I/O	Electrostatic discharge	CMOS sensor becomes inactive. Camera module does not function. Loss of video feedback to the operator.	2	Static charge from the body of the human operator can be discharged into the internal circuits of the camera module. Inadequate shielding from static charge.	2	Proper handling of the device during the manufacturing or product development stage.	Not likely to be detected.	10	40	Introduce proper shielding of the device during manufacturing phase.	Abdulrahman Saber Ali - 25/07/21	No actions taken	2	2	10	40
		Broken lens	Internal or external lenses may be damaged. Affects image quality as cracked parts of the lens will appear on the image. Severe damage will compromise the monitoring capabilities of the snake robot. Difficult to re-create a clean image.	8	Shock and vibration due to continuous operation of the snake robot. Mechanical stresses caused due to jolts or impact from rocks and gravel from surroundings. Dropping the robot from a height with head first impact. Mishandling of the camera module during snake robot development phases as well as component shipping/transportation.	9	Handle the snake robot and the camera module with care, especially during shipping, manufacturing and assembly phase.	Can be identified through image processing.	1	72	Replace camera module if damage is sustained as even a small damage will affect the image quality in the long term.	Muratcan Yuce - 25/07/21	No actions taken	8	9	1	72
		Video or image unclear	This affects the monitoring capabilities of the snake robot. Poor image and video quality.	1	Dirt, residue or foreign particles on the camera lens. Fogging or buildup of condensation inside the lens due to humid environments. Dust or sand particles lodged in the lens. Scratches on the lens from heavy interaction with the surroundings.	7	Maintain and clean camera lens with a dry cloth with soft, smooth fibre. Use proper cleaning fluids if required.	Can be detected during general maintenance of robot or during live operation. Can be detected from images captured during a mission.	2	14	Maintain and clean camera lens with a dry cloth with soft, smooth fibre. Use proper cleaning fluids if required.	Muratcan Yuce - 25/07/21	No actions taken	1	7	2	14
1-6-1	Ball bearings - 608RS miniature deep groove ball bearings. Mass of 0.012kg, dynamic load rating of 3.45kN and static load rating of 1.37kN. Used in the joint connected to the servo motor base plate.	Corrosion	Lowers bearing life and efficiency of snake robot movement	7	Ambient temperature, humidity, acidic substances, low quality lubricants, poor protection from environmental factors	6	Lubricate bearings at maintenance intervals. Snake robot must not be exposed to wet conditions or high levels of humidity	Formation of red and brown deposits on bearing rolling elements and parts. Significant increase in the vibration of the snake robot during operation which encourages wear	5	210	Proper cleaning and lubrication of bearings. Operating snake robot under dry conditions.	Shah Mohammed Isfar - 25/07/21	No actions taken	7	6	5	210
		Improper mounting - Press fit on PLA+, misalignment with the segment	Excessive friction between mated parts impede the servo motor operation. Joints can get jammed very easily	8	Poorly conducted assembly process, inaccuracy in 3D printed PLA+ parts, possible forms of contamination	3	Recheck dimensions of the hole for bearing on the segment and remove any foreign material or protrusions of 3D printed material. Check for loose fittings	Bearing protruding from the outer surface of the segment. Too much vibration at the joints due to unwanted interaction between mated parts.	2	48	Recheck the mounting positions of ball bearings.	Shah Mohammed Isfar - 25/07/21	No actions taken	8	3	2	48
		Contamination	Lowers bearing life and efficiency of snake robot movement. Foreign particles lodged in between parts may cause misalignment and hence more vibration	7	Lubricant for bearings are poorly stored and are exposed to foreign particles like sand particles, dirt, abrasive grit, dust or steel shavings and fillings found in the workshop environment	8	Filtering the lubricant to remove foreign materials that causes damage. Operating the robot in a clean work areas and using clean tools to conduct maintenance reduce contamination	Not likely to be detectable due to the minuteness of particles that may be jammed inside or around the bearing. Foreign particles may impede the normal movement of ball and this may cause vibrations.	6	336	Proper cleaning and lubrication of bearings and storage of lubricants under specified conditions. Lubricants must be sealed and protected from outside particles that may contaminate it.	Muratcan Yuce - 25/07/21	No actions taken	7	8	6	336

Severity	
Rank	Effect
10	Extreme
9	
8	High
7	
6	Moderate
5	
4	Slight
3	
2	
1	No effect

Occurrence	
Rank	Effect
10	Very high
9	High
8	
7	
6	Moderate
5	
4	Low
3	
2	Very low
1	

Detection	
Rank	Likelihood of detection
10	Almost impossible
9	Very remote
8	Remote
7	Very low
6	Low
5	Moderate
4	Moderately high
3	High
2	Very high
1	Almost certain

Table 20: Severity occurrence and detection ratings

3.5.9. Design for reliability

In this section, the various ways the snake robot can be improved in terms of its overall reliability will be discussed. There are many ways the reliability of a product can be increased and most of these methods involve the use of certain engineering assessment tools that can be used to define the state of the design, manufacturing, and testing phase of a product.

3.5.9.1. Design phase

In this phase the team aims to sculpt the desired product with requirement data obtained from the customers. In order to translate the needs and wants of customers into engineering specifications, the team used a House of Quality diagram, an engineering tool to correlate and link various objectives and provide a benchmark of the product with respect to competitors. An FMEA and HAZOP analysis, in relation to P-diagrams and boundary diagrams, is also crucial to understand the various modes of failure and ways of mitigating such failures throughout the development of the snake robot. Once this has been done, other tools and methods can be used to proceed deeper into the design process. Some of the ways the team plans to improve the design for reliability are listed as follows.

Load strength analysis (LSA) – This is a process conducted to understand the strength capabilities of the materials that undergo loading in the snake robot. In our project, some data for the load strength analysis will be obtained with the help of engineering simulation tools like ANSYS and SolidWorks. A preliminary simulation was done on the types of segments of the snake robot at varying levels of loading and temperature to gain some insight on the extremes of the system. With the values obtained, the team will decide whether to redesign certain mechanical parts of the snake robot to optimize it for the loading scenario studied but this will also heavily depend on the allowable budget of the project. This testing process will further help the team decide on how to protect vulnerable parts of the system from probable cases of shock and vibration, and this will be discussed in a later point.

Parts, materials, and process review (PMP) – Conduct a study to see whether the current parts, materials and manufacturing processes employed will help the team design a product with good reliable performance. Information on the cyclic loading, environmental effects as well as the wear of each component used in the snake robot must be obtained to have some data to compare with after testing the parts in house. This will give a better insight into the performance of the parts and components and will be a guide to the team should they consider a possible change in the design. The material selected for the snake robot shell (PLA+) must be reviewed as well as the 3D printing process involved with it.

Critical items list – Create a critical items list of all the parts and components that play a significant role in the overall reliability of the snake robot. This can be any mechanical or electronic parts. In the case of the snake robot, most of the technical uncertainty encompasses the 3D printed PLA+ parts, whose reliability is unknown and destructive testing is out of the question due to not enough samples in house and the inflated cost associated with reprinting many parts. The Arduino Uno is another critical item in the snake robot that governs the 3 main functions, namely, the control system, actuation, and monitoring. The possible causes of failure of these components must be studied carefully and in detail, together with the ways of tackling their failures. The FMEA of the snake robot must be updated and revised with respect to these components.

Load protection – Since the snake robot will undergo cyclic loading or a given duration of time, the 3D printed PLA+ shell is not enough to provide protection to the electronic devices housed in the tail section. A safety box design using inexpensive, readily available materials like bubble wraps can be considered to protect the certain parts from shock and vibration. Styrofoam can be used as a type of damper to support edges and corners of the electronic parts that otherwise are in direct contact with the PLA+ shell. The Styrofoam will absorb the shocks

and vibration from the snake movement, although not the best degree but it will prolong the life of the snake robot.

Component review – Carry out a study of all snake robot components. This involves obtaining manufacturers data, reliability data with the aid of handbooks and other reliable sources and documenting them. Performance history of any parts that have been reused, for example, the power supply unit used for the snake robot is obtained from the Department of Electrical and Electronics Engineering at EMU where staff or students have probably used it for laboratory and experimental purposes. It is better to consider the use of mature components as opposed to novel ones as their performance is assured with respect to the previous application but for a new component there could be many unknowns that later may translate into failure.

Adhesives – Adhesives may be used as an option to conduct minor repair works on the system during maintenance. For example, a cracked servo motor housing will cause foreign material, humidity or even water from the environment to cause serious damage to the internal parts of the motor, therefore, it is important to seal cracks with strong adhesives that bond easily rather than replacing the entire servo motor.

3.5.9.2. Manufacturing phase

In this phase, the snake robot design is brought to life via 3D printing of the PLA+ parts followed by the assembly and integration of all parts. Reliability is affected by how the components are handled during the manufacturing process as well as the way in which they are implemented. This also considers the variability of 3D printed components which are often the result of poor printer operation and maintenance. The accuracy of the FMEA analysis also affects how the manufacturing team make decisions, therefore it can be a source of error too. To avoid some of these issues and ensure better reliability of the snake robot, the following approaches to control human variation should be considered in the manufacturing process.

Operator control – The team member responsible for the 3D printing of the PLA+ shell will be responsible for keeping track of his work and methodologies. The operator of the 3D printer will manually check the dimensions, finishing and tolerances of the 3D printed shell and document his findings which can later be inspected by the production team to make sure everything is within order. The operator is also encouraged to track his progress via a statistical control chart and report to the team leader within a predefined period. This procedure will also motivate the team to work as one organism and in unison, each member aware of the others progress.

Simple charts – Apart from the introduction of SPC charts, updating existing charts and diagrams that help identify the causes and effects of technical problems faced during the manufacturing process. The Ishikawa diagrams, FMEA, HAZOP as well as Pareto charts must be drawn correctly and updated daily whenever there are new findings. This is a simple change that can result in a huge process improvement if done properly.

3.5.9.3. Testing phase

The reliability of the snake robot will be assessed via accelerated testing. This may be expensive as it will require more spare parts and components for field testing. The test will cover various environmental conditions like humidity, temperature, vibration, shock, dirt as well as sand, and will try to push specific boundaries of the normal operating conditions of the snake robot to understand its reliability. A detail of accelerated testing is mentioned in section 2.6 Reliability testing plan. However, apart from accelerated testing, Failure Mode Identification Testing (FMIT) must be conducted. This makes use of FMEA at system and subsystem level to aid in the detection of probable failure modes.

CHAPTER 4 - MANUFACTURING PROCESS

4.1. Manufacturing Process Selection

The manufacturing processes within this project include 3D printing, required for create the nose and tail cap, middle segments, nose, and tail servo mounts as well as the servo base plates, and hand tooling processes like screwing and drilling (if required). 3D printing was selected as opposed to acquiring off-the-shelf C-brackets because of some design uncertainties surrounding them. The team is more confident with the performance of the 3D printed parts since this snake robot design has been tested before by the original designer of the parts. One of our goals is to be environmentally friendly, therefore we decided to use biodegradable PLA+ as they degrade faster than normal plastic-based materials and are commonly used in 3D printing.

4.1.1. 3D printing process selection

Machines that transform 3D objects designed in a virtual environment into solid objects are called 3D Printers. Nose cap, Nose servo mount, servo segment, tail servo mount, tail cap and servo base plate parts of the snake robot will be manufactured by a 3D printer. 3D printers vary according to its type, production process and type of filament used. All of them have their own advantages and disadvantages. The process of 3D printing is known as additive manufacturing.

In this section, by comparing the differences of the 3D printers mentioned above, it will be clarified which 3D printer should be used. Before the comparison of 3D printer type, descriptions of each type are summarized in table 14.

Table 21: 3D-Printer Types.

(“3D Printer Parts - Buy All You Need For 3D,” n.d.)

Process	Description	Preferred Reason
Stereolithography (SLA)	Hardening parts of container of resin using light	Process is fast, detailed, and meticulous prints are obtained.
Digital Light Processing (DLP)	Hardening parts of container of resin using special projector	Process is extremely fast and clean and detailed prints are obtained.
Fused Deposition Modelling (FDM)	Before starting process, 3D model data is entered to the printer.	Fairly slow but it has recycling feature.
Selective Laser Sintering (SLS)	Works as SLA. Only difference is that SLS is using powder material. (Such as aluminum, nylon, glass, ceramic)	Rapid prototyping and product development.
Selective Laser Melting (SLM)	Powder metals are turned into 3D printing with high power laser. Aluminum, stainless steel and titanium can be used.	Metals with high strength can be easily printed.
Electron Beam Melting (EBM)	Like SLM. Only difference is power supplies usage. In EBM, an electron beam in a vacuum is used as power source. Metals are used as raw material.	Operates in extremely elevated temperatures.
Laminated Object Manufacturing (LOM)	Raw materials consisting of paper, plastic or metal	Supplies rapid prototyping.

	laminates which are melted with the help of heat and pressure and shaped by cutting with a computer-controlled knife or laser.	
--	--	--

3D printers of only SLA and FDM types are widely used and affordable. All the remaining 3D printers are used in the industry and extremely expensive type 3D printers. As cost is our priority, comparison of SLA and FDM type 3D printers are available in table 15 below.

Table 22: Comparisons of the 3D Printer Type

Concept 1→Worst 10→Best	Priority	Importance	SLA	FDM
Cost	9	9	5	8
Durability	8	8	8	8
High precision and smoothness	7	6	7	6
Tolerance	7	6	7	6
Total			27	28

3D printer types have been discussed according to their cost, 3D printers' durability, printed materials' high precision and smoothness and tolerance of the 3D printer properties compared in table 15. As a result, FDM type 3D printer was decided.

4.1.2. Shell material selection

The more important 3D printer type is, the more important the type of material to be printed. FDM type 3D printers generally use thermoplastics such as ABS, ABS+, PLA, PLA+ TPU, PETG, PEEK etc. Comparisons of some thermoplastics are available to select best filament material for snake robot parts in table 16. Because of cost and strength properties, team met on PLA+ according to table 17. The tables showing the mechanical properties of each material can be found in the appendix section.

ABS (Acrylonitrile Butadiene Styrene) is a 3D printing material that falls under the thermoplastic polymer range of materials. This is a lightweight material which is abrasion and corrosion resistant and commonly applicable for fused deposition modelling according to (“ABS Plastic Material for 3D Printing: FDM Thermoplastic Material,” n.d.). This material has a relatively low melting point (around 240 degrees Celsius) which proves to be both a beneficial property, in the sense that it is very machinable, as well as a drawback, in the sense that it cannot withstand prolonged exposure in heated environments.

Table 23: Mechanical properties of PLA and ABS.

According to (“(PDF) EVALUATION OF RAPID PRODUCT DEVELOPMENT TECHNOLOGIES FOR PRODUCTION OF PROSTHESIS IN DEVELOPING COMMUNITIES,” n.d.)

Properties	Units	ASTM	Common Material	
			PLA	ABS
Tensile Strength	MPa	D638-03	59	40
Elongation at Break	%	D638-05	7	50
Modulus of Elasticity	MPa	D638-04	3750	2600-3000
Izod Impact Strength	J/m	D256-06	26	34
Density	kg/mm ³		0.00105	0.00125
Cost per kilogram	Rand/kg	-	R 900	R 900
Colour		-	Various	Various

PLA (Polylactide) is the most common form of printing material used in prototype creation today and is also a competitor to ABS. Also, a part of thermoplastic polymer family, PLA is made from renewable plant materials like corn starch and sugar cane in contrast to other materials used within the industry and large-scale research projects which are composed of petroleum as mentioned in (“All You Need to Know about PLA for 3D Printing - 3Dnatives,” n.d.). When compared to the ABS filament, PLA has a relatively lower melting point (about 180 degrees Celsius) but is known to exhibit significantly higher flexibility and better finishing. PLA+ is simply a more enhanced version of PLA featuring improved mechanical properties like strength and thermal resistance. The team decided on PLA+ since it has the highest score with accordance to the project requirements as shown in the table below.

Table 24: Comparisons of the 3D Printer Filament type

Concept 1→Worst 10→Best	Priority	Importance	ABS	PLA	PLA+
Cost	9	9	6	6	8
Strength	7	6	7	7	8
Total			13	13	16

4.2. Detailed Manufacturing Process

In the following section, the steps taken to prepare and print the 3D snake parts are summarized. The main objectives here are to create a proof-of-concept prototype by integrating all the parts and components that are decided in the design phase with respect to the customer requirements. The joints, head and tail modules are 3D printed (additive manufacturing)

whereas the other components like the Arduino Uno microcontroller, camera module, infrared sensor as well as the servo motors were purchased off-the-shelf.

4.2.1. Detailed Manufacturing Process of 3D Printing

All parts that made up the assembly of the snake robot project (except ready-made ones) was printed on FDM type 3D printer. Besides, PLA+ type filament is used. In this section, steps of the manufacturing process of 3D printing are as followed.

1. Save the design file as an STL extension file.
2. Open design file that saved as an STL extension in *licer* program.
3. Slicer, instructs the 3D printer what to do in a language called “G-code”. After necessary operations are done on the slicer, file is transferred to the 3D printer via an USB or SD card.
4. Before starting the printing process, *nozzle* must reach a certain temperature.
5. The nozzle head forms the first layer since the path of the print head (extruder) is determined in the Slicer software. Same path is repeated many times and added to the first layer to create a 3D model of the design file.

Slicer is the general name of the programs that allow printing according to the specified properties of the object (or design). In other words, they give information to the printer on how to print this object (or design). Widely used ones are Simplify3D and Ultimaker Cura. The following settings and parameters have been used to generate one part in the slicer.

It was important for the team to acquire spare parts in order to mitigate the issue of a possible mechanical failure. The table below states the number of each part, the nose cap, nose servo mount, tail servo mount, servo base plate, servo segment and tail cap, within the final assembly of the snake robot as well as the number of spare parts.

Table 25: Number of parts in snake robot assembly and spare parts.

Part Number	Part Name	Number of Parts within Assembly	Number of Spares	Total Parts Printed
1-1	Nose Cap	1	2	3
1-2	Nose Servo Mount	1	2	3
1-7	Tail Servo Mount	1	2	3
1-3	Servo Base Plate	12	4	16
1-6	Servo Segment	11	3	14
1-8	Tail Cap	1	2	3

For the 3D-printing process Creality CR-10 FDM type 3D printer. The table below summarizes some of the characteristics and performance parameters for the 3D printer as specified in the product website. (“Buy Creality CR 10 3D Printer - CR Series 3D Printer,” n.d.)

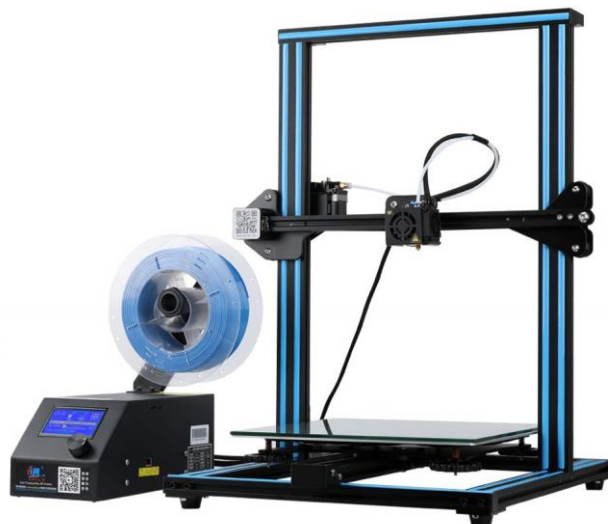

Figure 38: Creality CR 10.

(“Buy Creality CR 10 3D Printer - CR Series 3D Printer,” n.d.)

Table 26: Product parameters for the CR 10 3D printer.

(“Buy Creality CR 10 3D Printer,” n.d.)

Machine type	CR-10
Machine color	Orange, blue, black (optional)
Forming technology	FDM
Print size	300×300×400mm
N.W.	8.7Kg
G.W.	13.5Kg
Nozzle diameter	Standard 0.4mm
Control system	Win, xp, mac, vista, Linux
Software	Cura, Simplify3D, Repetier-host
File format	stl, obj, g-code
Print speed	Normal 60mm/s. Max 100mm/s
Filament diameter	1.75mm
Support filament	PLA/ABS/TPU/wood/carbon fiber/Copper
Power requirement	Input:110V-220V, Output 12V, Power 270W

Calibration:

1. Three end switches and couple motors are checked to see if they are plugged in correctly.
2. Wires of the motors are matched up with corresponding port through as shown in the figure below to see where each wire goes.
3. Placing an adhesion material on the bed
4. On settings screen, clicked on “auto home” option so that printer calibrated automatically to the home position.

- Adjusted the knobs under the table whenever it comes to 1 mm distance between nozzle and bed

Settings:

- In 3D-Printer menu, PLA+ material preheat option have chosen. Then, nozzle started to prepare for printing and additional settings are adjusted as shown in the figure below.
- In Slicer software, material, speed, travel, cooling, support, build plate adhesion, quality, walls, top/bottom, infill settings have been done.

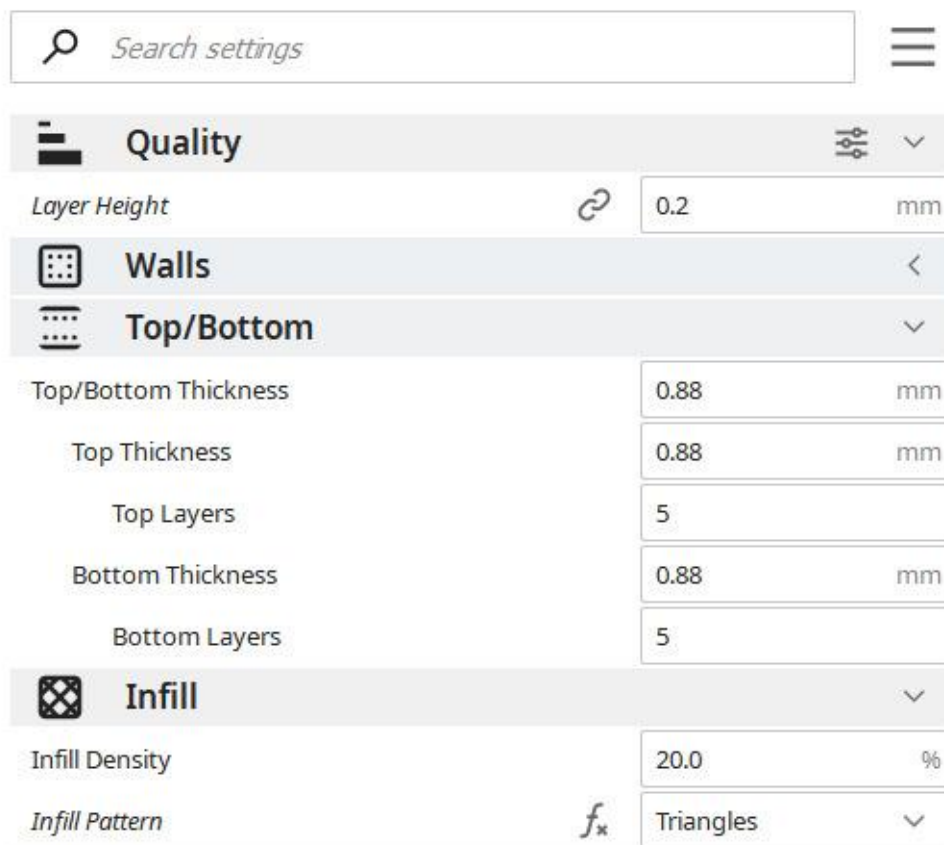

Figure 39: Printer settings displaying the thickness of the layers and infill characteristics.

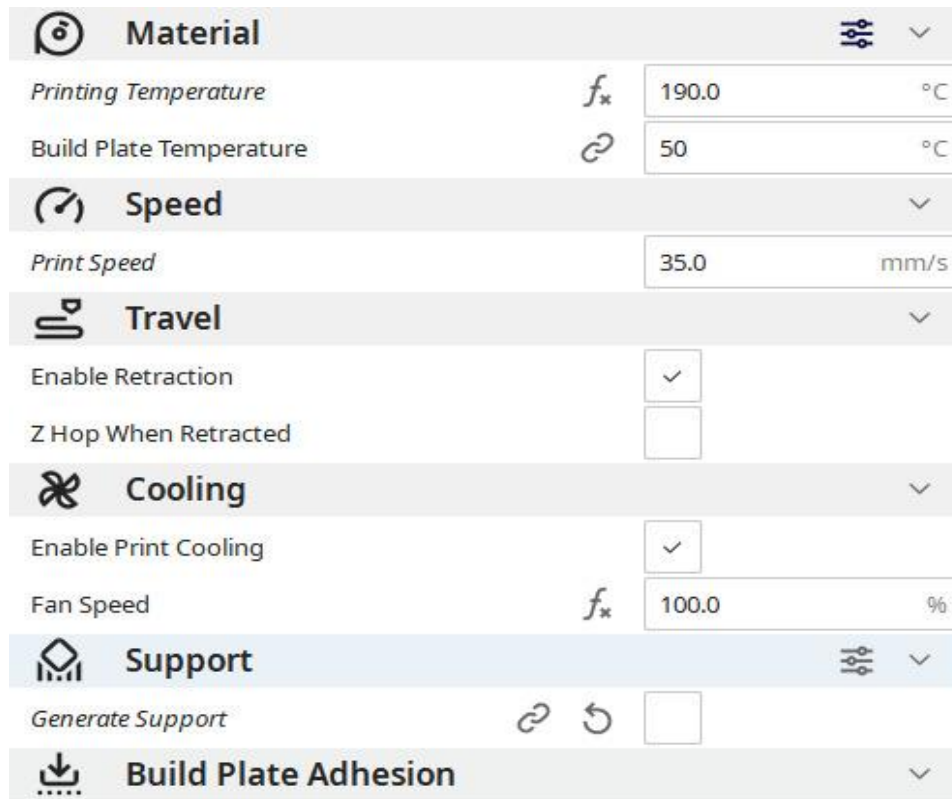

Figure 40: Printer settings displaying the material properties, speed of the printer and cooling.

Printing:

8. After settings are done in Slicer, G-Codes that automatically created with settings by Slicer took into micro-USB card to put into 3D-Printer.
9. Then, PLA+ filament plugged into extruder.
10. Started to print.

After 3D-Printing, team decided to compare measurements of 3D printed parts with design to see if there are any parts required to re-print. Parts were fitted with ball bearing and servo motors to check the overall tolerance of the parts. Some of the parts, especially the servo segment, proved to be slightly smaller, therefore it was difficult to fit the bearings. The small section was heated with a flame for a few seconds and melted to fit the ball bearings. This is an advantage because the melted PLA bonds better after being reheated and maintains its altered shape.

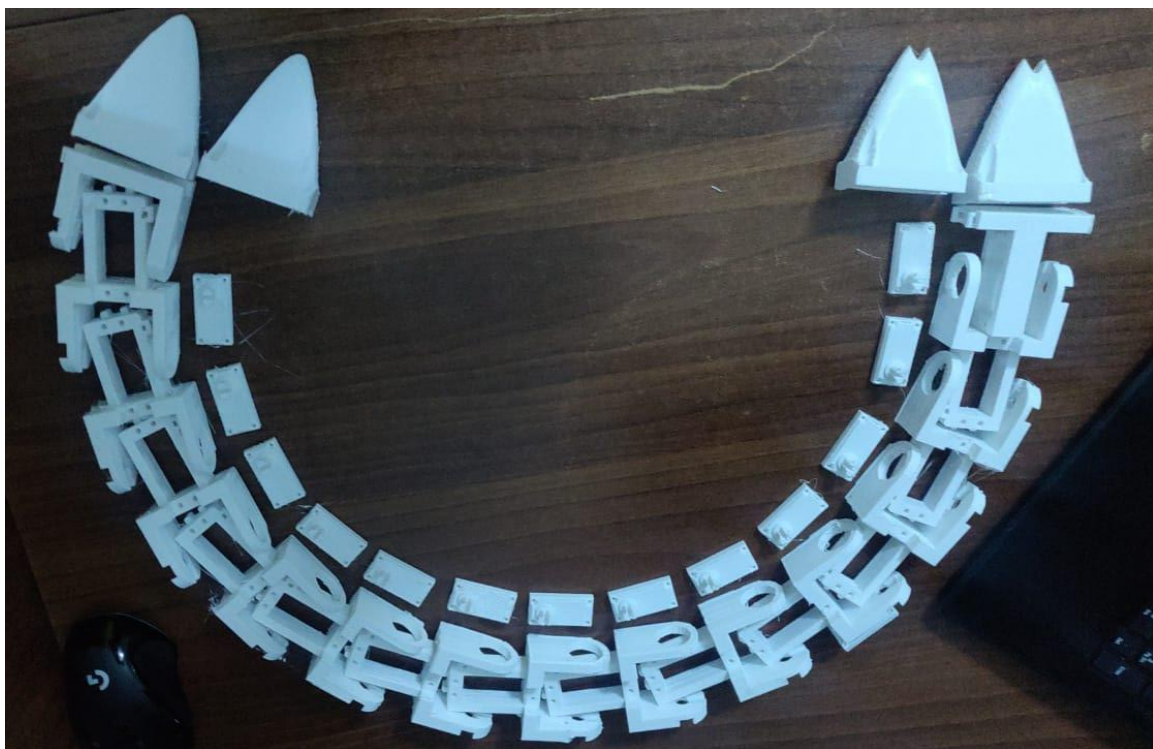

Figure 41 - 3D printed parts arranged in order of assembly.

4.2.2. Snake Robot Assembly and Locations of the Electronic Components

Electronic components that are used in this project are given with their locations in figure 41.

1. Adjustable Power Supply
2. Gauge wires (black and red)

3. IR Remote Controller's receiver
4. Servo Motors
5. Wi-Fi Camera
6. Arduino UNO
7. Electrolytic Capacitor
8. Male header pins
9. IR Remote Controller

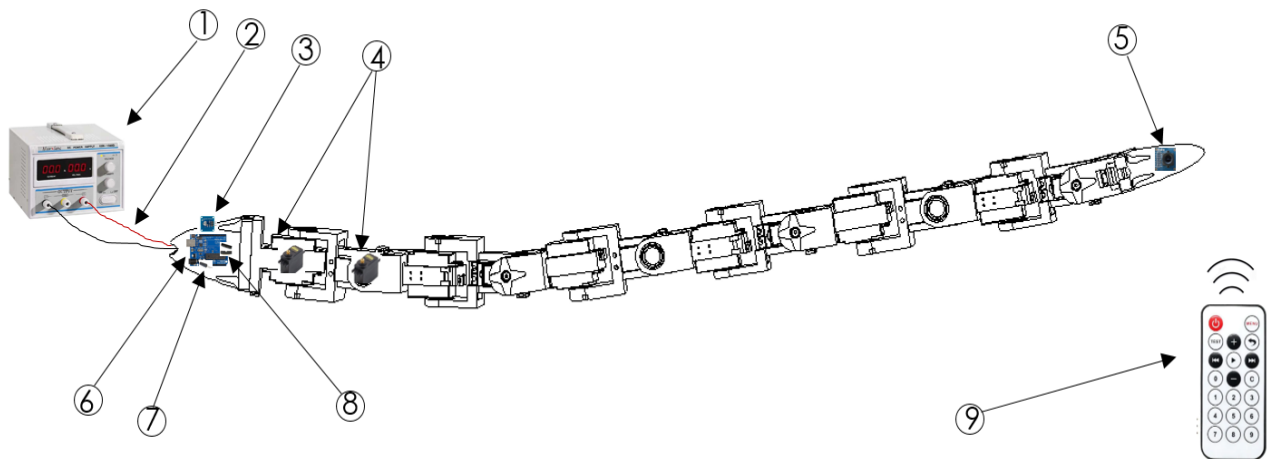

Figure 42: Locations of electronic components

1. **Adjustable Power Supply:** because of supply's voltage and current are adjustable, it allows that snake robot to be tested within a certain range. Relevant data are given as follows:

*Table 27: Properties of KXN-3020D Adjustable Power Supply
 (“Zhaoxin - Karakoy Elektronik,” n.d.)*

Voltage Output	0-30V
Current Output	0-20A
Input voltage	AC 220V± 10% 50Hz/60Hz (also can be AC 110V± 10% 50Hz/60Hz if required)
Weight	6.84kg
Dimensions(mm)	375×263x164
Working Condition Temperature:	-10-40 Degree Celsius Relative humidity: <90%

2. **Gauge Wires:** Black and red wire are used. They have 3 mm diameters. Max current that can pass through on wire is 35 A. Each of them has 2.5 m, totally 5 m length.
3. **IR Remote Controller’s receiver and IR Remote Controller:** Working frequency is 38 kHz, distance is 8 meters and viewing angle is 60 degrees.
4. **Servo Motors:** High-Torque MG996R type servo motor has been used. Specifications of MG996R has been summarized in the table x.
5. **Wi-Fi Camera:** OV767 type Wi-Fi camera module was used. It has 640 x 480 VGA resolution and needs to 1.7 V to 3 V power supply I/O.
6. **Arduino UNO:** It has 14 I/O digital pins (6 PWM output) and 6 I/O analog pins.
7. **Electrolytic Capacitor:** Has a voltage range from 6.3V to 100V and a rated capacitance range from 0.47μF to 18000μF.

8. Male Header Pins: It has 30 pins and space between each pin is 2.54 mm.

After all 3D-Printer process is done, the team went for assembly of electrical components, wiring and additional mechanical parts.

Mechanical Parts: Before electrical components' assembly and wiring, all additional mechanical parts that apart from 3D-printed parts like bearings (see figure below) and screws prepared for assembly.

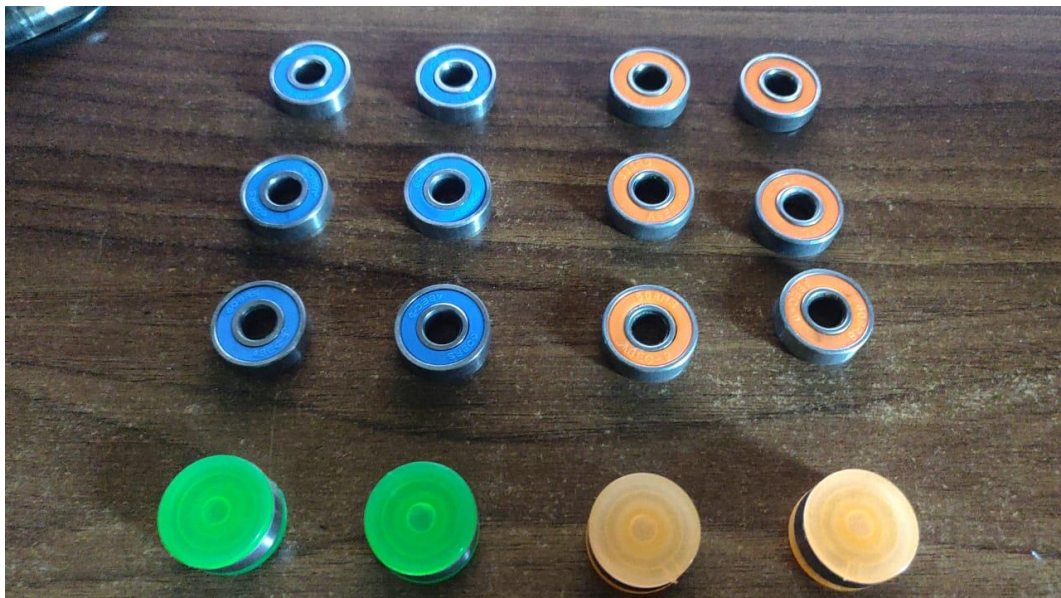

Figure 43 - Ball bearings to be fitted.



Figure 44 - Servo horn.

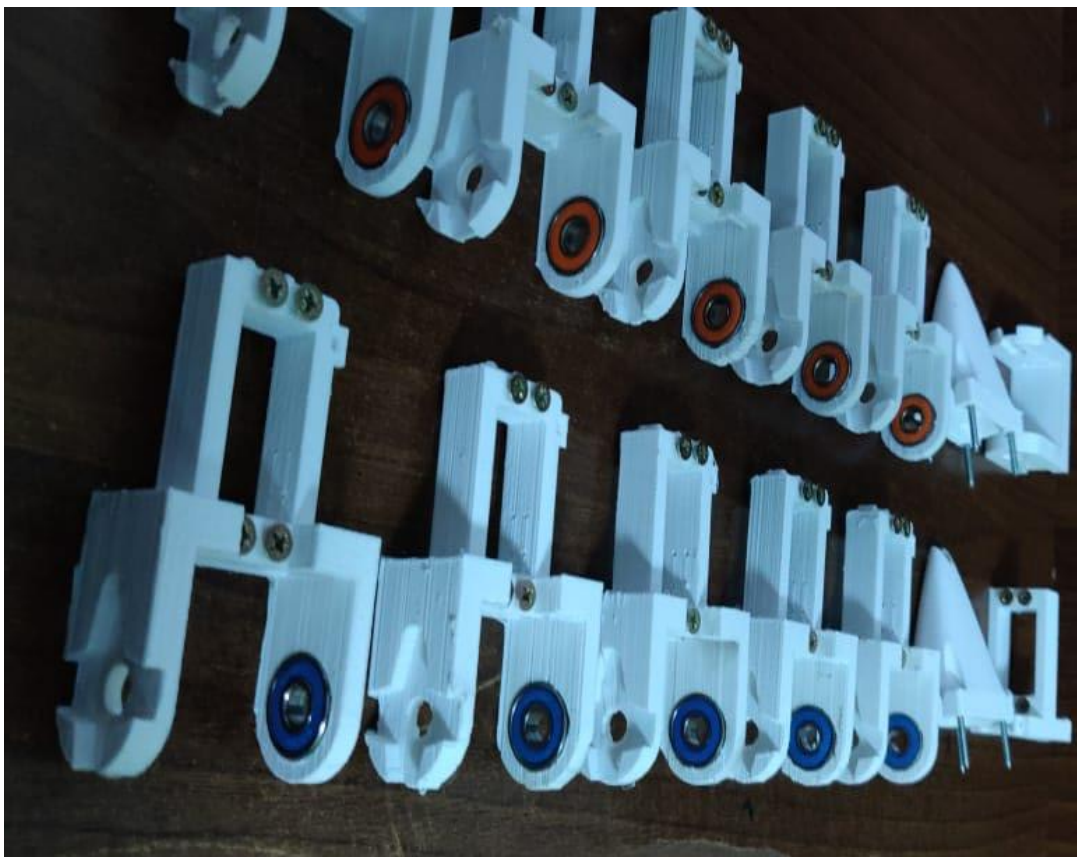

Figure 45 - Servo segments fitted with ball bearings and screws.

Electronic Components and wiring: Electronic components that assembled are MG996R Servo Motors, Arduino Mega, Capacitor, Power Supply, and IR Remote Controller. Wiring is done.

1. All 3D printed parts painted with black colored spray and dried for 24 hours.



Figure 46 - Fresh printed 3D segment and sprayed segment.

2. After parts are dry, first operation was replacing the bases of servo motors with servo base plate for locating bearings onto base plate through knob on it. Then, screws are tightened with servo motors and servo segments together. Process applied for all segments.
3. 3 Different colors of wire have been used. Yellow for PWM signals, Brown for Ground, Blue for Power. 2 different buses have been drawn all along the snake with offset and each servo connected these busses with their available inputs. After servos matched up with busses, connected to Arduino's 5V and Ground pins. For PWM signals should have been

single for each servo motor. That's why, every servo motor is connected to suitable Arduino pins one by one.

4. For powering the Arduino, power supply's 5V, ground and 20 Amps pins used. Capacitor has been added between power supply and Arduino for protecting the snake and Arduino from high voltage.

CHAPTER 5 - PRODUCT TESTING PLAN

Testing is required to get an idea of the benchmark performance of the snake robot and the team plans to do this at a system level as well as a subsystem level. In system level we aim to test the performance of the entire snake robot. This will be done in the following ways and will be improved in the future as the project progresses to the testing phase:

- Performing a servo test of the snake robot to check whether all the servo motors are operating properly.
- Performing a test of the snake robot successfully navigating from point A to point B in a flat plane, using movement type M (M is the type of movement of the snake if there are more than one types of snake locomotion involved).
- Performing a test of the snake robot successfully navigating from point A to point B in an inclined plane, using movement type M (M is the type of movement of the snake if there are more than one types of snake locomotion involved).
- Performing a test of the snake robot navigating from point A to point B in a pipe of diameter D placed on a flat plane.
- Performing a test of the snake robot navigating from point A to point B in a pipe of diameter D placed on an inclined plane.

In subsystem level we aim to test the performance of individual components of the snake robot. These components include the power supply, the infrared sensor, the individual servo motors as well as the remote control. Once the data collected in the tests mentioned above suggests that the snake robot will be able to perform properly in the field, we will continue onto the next stage of the product life which is the marketing phase.

5.1. Verification plan of the objectives of the project

- **Design for cost** – Review and conduct more detailed cost analysis to make sure quality, inexpensive and readily available products and materials have been used in the design of the snake robot. This will also consider the performance achieved by these selected materials and components.
- **Design for manufacturability** – Review the manufacturing processes used in the making of the snake robot and make it more economic and easier to assemble. Materials and tools apart from the 3D printer must be readily available to the manufacturer or can be acquired from the local markets. Review the energy usage expenditures and plan accordingly to pave way for a more energy efficient process.
- **Design for reliability** – Conduct a more detailed reliability analysis of the snake robot. Only the reliability analysis was conducted but the team must prepare to collect data and conduct a reliability of the mechanical parts mainly composed of 3D printed PLA+ parts. Conduct destructive and field tests as well as record data relating to defective or imperfect 3D printed parts in order to calculate failure rate of PLA+ parts. Conduct a more detailed PFMEA and DFMEA for the snake robot. Review the system RAMS. Review the fault tree of the snake robot system and identify the cut sets.
- **Design for safety** – Review the design of the snake robot and identify parts and components that can cause potential harm to the user and devise a plan to make them safer.
- **Design for environment** – Minimize harmful by products, waste materials as well as energy usage expenditures in the design and manufacturing phase of the snake robot. Plan for more efficient energy consumption as well as the proper disposal of parts like batteries and 3D printed PLA+ shell.

5.1.1. Test of electronic components

In order for the Snake Robot to operate effectively and functionally in line with its purpose, some tests should be carried out before the robot is implemented. Purpose of the tests to be done is to prevent problems that may occur and to ensure the safety of the users. All electronic components used in project must be tested and the methods are summarized below.

- **Servo Motor** – Servo motors can be tested in 3 different ways. First method is with using additional circuit. Figure 42 shows how the servo motor test circuit is implemented and which circuit components are used. Secondly, in the servo motor test using software, after the circuit is implemented on the Arduino board, the required servo motor features (rotational speed, angle of rotation of the arms etc.) can be tested with necessary codes. Finally, small, inexpensive, and easy to use servo motor tester device can be used. Servo motor tester device is depicted in figure 43. Aim of this test is to make sure that all 12 servo motors are working properly. Ensuring that the arms of the servo motors can give the desired angle in the desired axis and the result of measuring the voltage and current values passing over the servo motors with a multimeter and comparing measurements with datasheets indicates that the use of servo motors should be started after obtaining same (or very close) values.

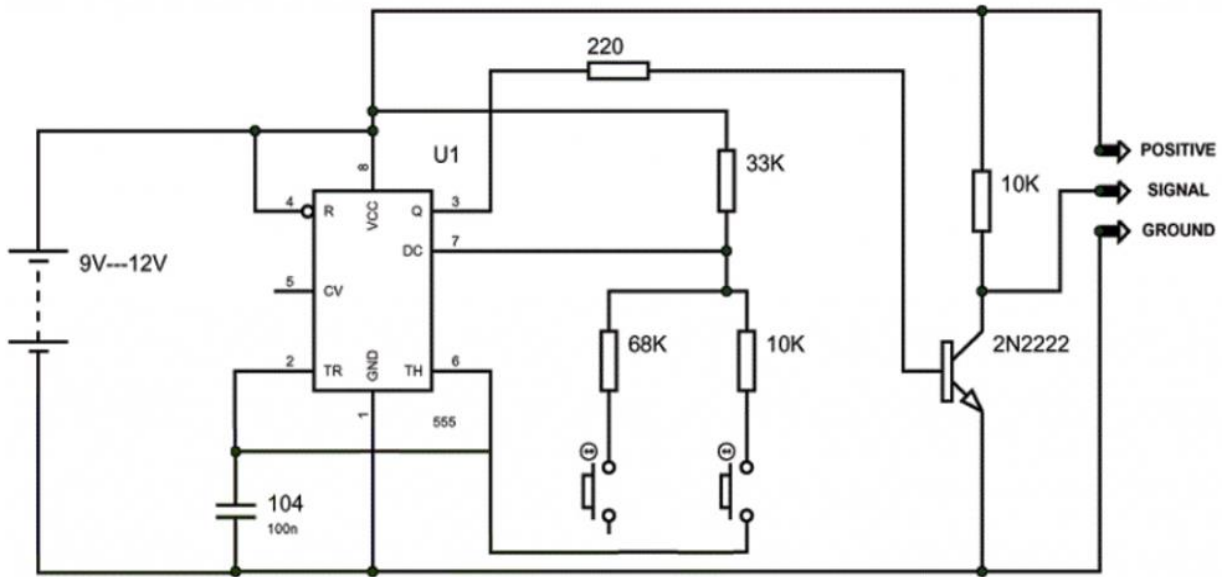

Figure 47: Servo Motor Test Circuit

(“Servo Motor Tester Circuit Diagram Using IC 555,” n.d.)



Figure 48: Servo Motor Tester

(“Amazon.Com: HiLetgo 3pcs RC Servo Tester 3CH Digital Multi ECS Consistency Speed Controller Checker Adjustment Steering Gear Tester CCPM Master for RC Helicopter Car Boat: Arts, Crafts & Sewing,” n.d.)

- **Arduino** – Arduino is a microcontroller board that includes 13 pins in total. However, digital signal is sent to 13th pin turns on or off a test LED on the Arduino board. This led is also a very useful in terms of understanding that Arduino card is programmable. If the Arduino LED is blinking smoothly at the intervals written in the code, it is understood that the Arduino board is working properly.
- **IR Remote Controller** – In order to test the IR remote control, the test circuit should be implemented, and the LEDs should be changed by means of the remote control. In the circuit we have created below, it lights up red when the 1 key is pressed, green when the 2 key is pressed and blue when the 3 key is pressed, and if these colors turn on, it means that the connection of the IR remote control with its receiver has been established properly. A simple test circuit is established using Arduino, led, resistor and jumper cables and is shown in the figure 44:

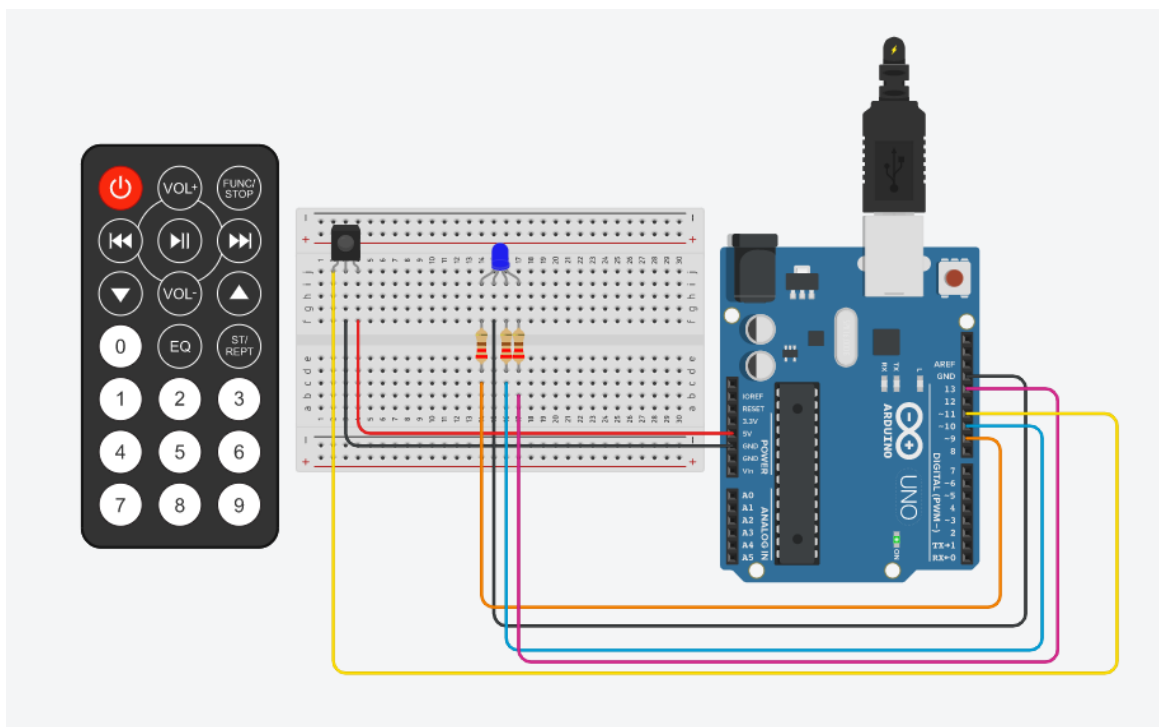

Figure 49: Simple test circuit for IR controller in Tinkercad

5.1.2. Test of 3D printer

- **3D printer** – The tolerance gauge test is used to test the accuracy of a FDM type 3D printer before printing essential parts. The part shown in Figure 46 has certain features. Knowing these features before talking about the test will make the test easier to understand. These features are as follows:
 - a. Part shown in the figure 46 allows to measure both tolerance and clearance values.
 - b. It has 6 gaps including a center one. Clearance values are starting at 0.5 mm going down to 0.15.
 - c. There is a protrusion outside of each clearance circle and this protrusion can move freely to the right and left. If it is hard to free protrusions up, then it means the 3D printer is used prints the part at that clearance value.
 - d. This test is only for FDM type 3D printers.

Testing:

- Before the main parts are printed, tolerance gauge test part should be printed first.
- After printed the part, clearance value should be checked.
- If protrusion is stuck, then stuck protrusion value indicates the 3D printer's clearance value.
- Finally, according to indicated clearance value, dimensions of the design can be whether increased or decreased for manufacturing of parts that are as accurate as possible.



*Figure 51: Clearance values of Tolerance Gauge Test part
("Clearance and Tolerance 3D Printer Gauge," n.d.)*

5.2. Verification plan of the applied engineering standards

- 1. ISO/IEC/IEEE FDIS 29119-4:** Software and systems engineering — software testing — PART 4: Test techniques
- 2. ISO/IEC/IEEE 29119-4:2015:** Software and systems engineering — Software testing — PART 4: Test techniques
- 3. ISO/WD 5363:** Robotics — Test methods for Walking RACA Robot
- 4. ISO 9283:1998:** Manipulating industrial robots — Performance criteria and related test methods
- 5. ISO 9787:2013:** Robots and robotic devices — Coordinate systems and motion nomenclatures
- 6. ASTM D495-14:** Standard Test Method for High-Voltage, Low-Current, Dry Arc Resistance of Solid Electrical Insulation
- 7. ASTM D150-18:** Standard Test Methods for AC Loss Characteristics and Permittivity (Dielectric Constant) of Solid Electrical Insulation
- 8. ASTM D2303-20e1:** Standard Test Methods for Liquid-Contaminant, Inclined-Plane Tracking and Erosion of Insulating Materials
- 9. IPC-MF-150:** Metal Foil for Printed Wiring Applications.

CHAPTER 6 – RESULTS AND DISCUSSION

In the following project, the team faced a lot of challenges when manufacturing the parts as well as finding the necessary electrical components. The availability of the components is very poor in the current location, therefore, the parts had to be treated with care and caution. One of the challenges was creating a simulation of the snake robot on MATLAB and Simulink. This was due to defective mating characteristics in the 3D designed parts on the SolidWorks software. However, the snake robot is a promising device that can be used for surveying and probing restricted and inaccessible areas. The team also conducted research on the snakeskin, a material placed on the surface of the exposed snake servo segments in order to achieve a higher level of grip and protection against hard impacts on the snake robot. This can be seen on the two prototypes developed, the SR002 – Light Duty and the SR003 – Heavy Duty. Friction foam of thickness 2mm on the SR002 and 5mm on the SR003 respectively and conducted tests to observe their performance. The SR002 is more suitable for high grip terrain, due to its coarse surface, whereas the SR003 is built to suit friction deficient environments and heavy impacts from external obstacles. The reliability of the device can be improved by incorporating metal gear servos. Some of the servos used by the team consisted of plastic gears that broke and deteriorated over time as they are exposed to a lot of torque. The wiring of the system was also a challenge as some of the wiring could not be contained within the skeletal structure of the snake robot. This must be optimized in the future with thinner wires, and zip ties and possibly the use of a solder in unison with heat shrink tubing in order to make it safe for the operator and reliable as well. The camera on the head of the snake must be reconsidered and a smaller version must be acquired. This is due to the small space inside the snake head. However, this issue can also be solved by redesigning the snake head to fit the camera module. In addition, as seen in the subsystem reliabilities computed in section 2, the reliability of the structural subsystem is critically low. This mean more work must be done in the design of the

snake robot as well as accelerated testing on the 3D printed mechanical parts to obtain better failure data. The 3D parts could sustain a significant amount of stress as predicted in the ANSYS loading simulations, except for a few occasions when the bearing mount fractured under cyclic loading. This is due to uneven layering done by the 3D printer. This issue can be solved by running and maintenance on the 3D printer and refilling the PLA. Cleaning the printer parts and the nozzle and separating inconsistent output of 3D printed parts will assure longer performance of output parts. Furthermore, spray painting the parts was a good way of making them more resistant to dust, thermal effects, and friction from the environment. The electronics subsystem reliability found was expected but can be improved by changing the electronics architecture as well as introducing some redundancy into the system. The overall snake robot reliability was very low because of the high density of series configurations involved, especially in the structural subsystem, which compromised the resultant reliability of the snake robot. Furthermore, apart from a system design FMEA, a process FMEA must be made to explore possible modes of failure and their causes. HAZOP analysis must also be expanded to identify deviations that may cause harm to the operator which were not mentioned in this report due to lack of data. The fault tree analysis must be revised and the cut-sets, basic events that lead to no movement of the snake robot, must be identified. All charts and diagrams must be revised and updated throughout the current design, manufacturing, and testing phase to maximize failure detection and mitigation.

CHAPTER 7 – FUTURE WORKS

This report has demonstrated the Snake Robot prototype. It shows concept selections, design and necessary calculations and their significance of the snake robot project. In addition, it describes all the manufacturing process, including the manufacturing plan, in all its details. In addition, the comparison of the values obtained during testing and simulation with the real values explained. Besides, all possible problems and their solutions faced while developing this project is described. All kinds of documents are provided that can be accessed by a user who has no knowledge of the project and wants to learn. This project also includes FMEA, HAZOP, and reliability block diagrams in details to find the solutions to the problems that user may encounter. In the future models, the team plans to incorporate stronger and reliable servo motors that contain strong metal gears. This will further increase the reliability of the snake robot. The wiring of the snake can be further optimized to make it safer for the operator to handle. More servo motors will be added to the current configuration to increase the flexibility, and this will allow the team to experiment with more complex snake locomotion. Adding more servos and making the snake robot longer will allow it to climb pipes and trees as well as scale small obstacles. Proximity sensors will be added in relation to the Raspberry Pi and ESP to make the snake robot completely autonomous and capable of exploring confined spaces without the need for manual operation. A camera will be added on the head of the snake in order to capture and record the mission in high definition. The camera will provide a live feed over a WIFI connection, and the user will be able to change the camera settings and conditions

from a remote location. The snake structure will be completely redesigned with a focus to make it lighter, durable, and waterproofed for underwater applications. Fins and other aquadynamic parts that will allow the snake to explore rivers and ponds to acquire data on the level of toxicity or pollution in the water body. The current snake robot prototype features an external power supply unit which is tethered to the robot from the tail segment. This decreases the remote operability of the snake robot in general but was a cost-effective measure at the inception of the project. In the future iterations of the snake robot, the team aims develop and introduce independently powered and actuated segments. This design method aims at making the snake robot highly modular since segments can be added or removed during downtime depending on the operator's objectives, and segments can be attached without the concern for a manual adjustment to the power supply, if it is within the load capacity of the servo motors. Incorporating an independent system such as this also means the snake robot can still be operational in the event where damage is conducted on one or more of the segments. The wiring in such a design is also minimal, compact, and confined within its own independent segment, and does not intersect other segment wiring. This future model will have a hollow segment design, which also allows more space to introduce redundancy measures per segment to the snake robot.

REFERENCES

- 0.3MP OV7670 Camera Module with High Quality SCCB Connector – Gona Kart. (n.d.). Retrieved May 24, 2021, from https://www.gonakart.in/products/2269_0-3mp-ov7670-camera-module-with-high-quality-sccb-connector
- 3D Printer Parts - Buy All You Need For 3D. (n.d.). Retrieved May 30, 2021, from <https://www.robotistan.com/3d-printer-parts>
- ABS Plastic Material for 3D Printing: FDM Thermoplastic Material. (n.d.). Retrieved May 24, 2021, from <https://www.sculpteo.com/en/glossary/abs-definition/>
- ACM-R5H - ROBOTS: Your Guide to the World of Robotics. (n.d.). Retrieved May 19, 2021, from <https://robots.ieee.org/robots/acm/?gallery=photo4>
- All you need to know about PLA for 3D printing - 3Dnatives. (n.d.). Retrieved May 24, 2021, from <https://www.3dnatives.com/en/pla-3d-printing-guide-190820194/>
- Amazon.com: HiLetgo 3pcs RC Servo Tester 3CH Digital Multi ECS Consistency Speed Controller Checker Adjustment Steering Gear Tester CCPM Master for RC Helicopter Car Boat: Arts, Crafts & Sewing. (n.d.). Retrieved May 29, 2021, from https://www.amazon.com/HiLetgo-Consistency-Controller-Adjustment-Helicopter/dp/B07TQSKLBK/ref=sr_1_3?dchild=1&keywords=servo+motor+tester&qid=1621953976&sr=8-3
- Arduino - Board. (n.d.). Retrieved May 20, 2021, from <https://www.arduino.cc/en/reference/board>
- Arduino based Snake Robot Controlled using Android Application Project. (n.d.). Retrieved May 10, 2021, from <https://nevonprojects.com/arduino-based-snake-robot-controlled-using-android-application/>
- Bioinspired Robotic Snake : 16 Steps (with Pictures) - Instructables. (n.d.). Retrieved May 10, 2021, from <https://www.instructables.com/Bioinspired-Robotic-Snake/>
- Borenstein, J., & Borrell, A. (2008). The OmniTread OT-4 serpentine robot. *Proceedings - IEEE International Conference on Robotics and Automation*, 1766–1767. <https://doi.org/10.1109/ROBOT.2008.4543456>
- Borenstein, J., Hansen, M., & Borrell, A. (2007). The OmniTread OT-4 Serpentine Robot-Design and Performance. *Journal of Field Robotics*, 24(7), 601–621. <https://doi.org/10.1002/rob.20196>
- Buy Creality CR 10 3D Printer. (n.d.). Retrieved January 9, 2022, from <https://www.creality3dofficial.com/products/creality-cr-10-3d-printer>
- Buy Creality CR 10 3D Printer - CR Series 3D Printer. (n.d.). Retrieved February 1, 2022, from <https://www.creality3dofficial.com/products/creality-cr-10-3d-printer>
- Chan, L.-K., & Wu, M.-L. (n.d.). *Quality function deployment: A literature review*. Retrieved from www.elsevier.com/locate/dsw
- Chap 1: OmniTread. (n.d.). Retrieved May 21, 2021, from http://mrl.engin.umich.edu/00MoRob_6.html

- Chen, I. M., & Yim, M. (2016). Modular robots. In *Springer Handbook of Robotics* (pp. 531–542). Springer International Publishing. https://doi.org/10.1007/978-3-319-32552-1_22
- Clearance and Tolerance 3D Printer Gauge. (n.d.). Retrieved May 29, 2021, from <https://www.makersmuse.com/clearance-and-tolerance-3d-printer-gauge>
- CMU's Snakebot Goes for a Swim. (n.d.). Retrieved May 21, 2021, from <https://www.cmu.edu/news/stories/archives/2021/april/snake-robot.html>
- Dasgupta, B., & Mruthyunjaya, T. S. (2000). Stewart platform manipulator: A review. *Mechanism and Machine Theory*, 35(1), 15–40. [https://doi.org/10.1016/S0094-114X\(99\)00006-3](https://doi.org/10.1016/S0094-114X(99)00006-3)
- Embedded Computer Architecture 5 SAI 0 Micro Processor. (n.d.). Retrieved June 30, 2021, from <https://slidetodoc.com/embedded-computer-architecture-5-sai-0-micro-processor-2/>
- Enner, F., Rollinson, D., & Choset, H. (2012). Simplified motion modeling for snake robots. *Proceedings - IEEE International Conference on Robotics and Automation*, 4216–4221. Institute of Electrical and Electronics Engineers Inc. <https://doi.org/10.1109/ICRA.2012.6225163>
- Hopkins, J. K., Spranklin, B. W., & Gupta, S. K. (2009). A survey of snake-inspired robot designs. *Bioinspiration and Biomimetics*, 4(2). <https://doi.org/10.1088/1748-3182/4/2/021001>
- How to Use OV7670 Camera Module With Arduino? : 4 Steps - Instructables. (n.d.). Retrieved May 29, 2021, from <https://www.instructables.com/How-to-use-OV7670-Camera-Module-with-Arduino/>
- human skeleton | Parts, Functions, Diagram, & Facts | Britannica. (n.d.). Retrieved May 21, 2021, from <https://www.britannica.com/science/human-skeleton>
- ISO - ISO 14040:2006 - Environmental management — Life cycle assessment — Principles and framework. (n.d.). Retrieved April 25, 2021, from <https://www.iso.org/standard/37456.html>
- Ji, Y., Kim, J., Kim, J., Lee, M., Noh, J., Jeong, T., ... Pae, S. (2018). Reliability characterization of advanced CMOS image sensor (CIS) with 3D stack and in-pixel DTI. *IEEE International Reliability Physics Symposium Proceedings, 2018-March*, 3D.31-3D.34. Institute of Electrical and Electronics Engineers Inc. <https://doi.org/10.1109/IRPS.2018.8353570>
- Lees' Loss Prevention in the Process Industries: Hazard Identification ... - Frank Lees - Google Books. (n.d.). Retrieved June 30, 2021, from <https://books.google.com.cy/books?id=UDAwZQO8ZGUC&pg=PA8&dq=IR+sensor+failure+rate&hl=en&sa=X&ved=2ahUKEwi9wJCWur3xAhUAgf0HHdpaBXUQuwUWAHoECAYQBw#v=onepage&q=IR%20sensor%20failure%20rate&f=false>
- Li, M., Cao, Z., Zhang, D., & Fu, Y. (2016). 3-DOF bionic parallel mechanism design and analysis for a snake-like robot. *2016 IEEE International Conference on Robotics and Biomimetics, ROBIO 2016*, 25–30. Institute of Electrical and Electronics Engineers Inc. <https://doi.org/10.1109/ROBIO.2016.7866272>
- Liu, J., Tong, Y., & Liu, J. (2021). Review of snake robots in constrained environments. *Robotics and Autonomous Systems*, 141, 103785. <https://doi.org/10.1016/j.robot.2021.103785>
- Matsuno Lab Kyoto University - 蛇のページ. (n.d.). Retrieved May 19, 2021, from http://www.mechatronics.me.kyoto-u.ac.jp/modules/kenkyu/index.php?content_id=27&ml_lang=en

- MG996R High Torque Metal Gear Dual Ball Bearing Servo. (n.d.).
- MIT's Modular Robotic Chain Is Whatever You Want It to Be - IEEE Spectrum. (n.d.). Retrieved May 19, 2021, from <https://spectrum.ieee.org/automaton/robotics/robotics-hardware/modular-robotic-chain-is-whatever-you-want-it-to-be>
- MODULARITY | meaning in the Cambridge English Dictionary. (n.d.). Retrieved May 19, 2021, from <https://dictionary.cambridge.org/dictionary/english/modularity>
- NASA - Snakebot. (n.d.).
- n-link snake robot Figure 2. Free body diagram of n-link snake robot. | Download Scientific Diagram. (n.d.). Retrieved May 30, 2021, from https://www.researchgate.net/figure/n-link-snake-robot-Figure-2-Free-body-diagram-of-n-link-snake-robot_fig1_277762859
- (PDF) Design, Construction and Dynamic Modeling of a Snake Robot. (n.d.). Retrieved May 30, 2021, from https://www.researchgate.net/publication/277762859_Design_Construction_and_Dynamic_Modeling_of_a_Snake_Robot
- (PDF) EVALUATION OF RAPID PRODUCT DEVELOPMENT TECHNOLOGIES FOR PRODUCTION OF PROSTHESIS IN DEVELOPING COMMUNITIES. (n.d.). Retrieved May 24, 2021, from https://www.researchgate.net/publication/319489894_EVALUATION_OF_RAPID_PRODUCT_DEVELOPMENT_TECHNOLOGIES_FOR_PRODUCTION_OF_PROSTHESIS_IN_DEVELOPING_COMMUNITIES
- Power Supply. (n.d.). Retrieved May 30, 2021, from <https://www.robotistan.com/power-supply>
- Reliability Analytics Toolkit. (n.d.). Retrieved June 30, 2021, from <https://reliabilityanalyticstoolkit.appspot.com/>
- Reliability Engineering Handbook - Dimitri Kececioglu - Google Books. (n.d.). Retrieved June 30, 2021, from https://books.google.com.cy/books?id=r_kK7v6FSIMC&pg=PA286&dq=MTBF+of+servo+motors&hl=en&sa=X&ved=2ahUKEwj0yaTqvr3xAhW0hf0HHQFeAdYQuwUwBXoECAQQBw#v=onepage&q=MTBF%20of%20servo%20motors&f=false
- Rosendo, D., Gomes, D., Santos, G. L., Goncalves, G., Moreira, A., Ferreira, L., ... Wildeman, M. (2019). A methodology to assess the availability of next-generation data centers. *Journal of Supercomputing*, 75(10), 6361–6385. <https://doi.org/10.1007/s11227-019-02852-3>
- Safe, Autonomous and Intelligent Vehicles - Google Books. (n.d.). Retrieved June 30, 2021, from <https://books.google.com.cy/books?id=Sfd5DwAAQBAJ&pg=PA7&dq=CMOS+camera+sensor+failure+rate&hl=en&sa=X&ved=2ahUKEwiEr4GluL3xAhWFB2MBHQRBCDQQuwUwBXoECAUQBg#v=onepage&q=CMOS%20camera%20sensor%20failure%20rate&f=false>
- Sarson-Lawrence, J., Sabatini, R., Clothier, R., & Gardi, A. (2014). Experimental determination of low-cost servomotor reliability for small unmanned aircraft applications. *Applied Mechanics and Materials*, 629, 202–207. Trans Tech Publications Ltd. <https://doi.org/10.4028/www.scientific.net/AMM.629.202>
- Semantics of the Weibull distribution (the bathtub curve) | Download Scientific Diagram. (n.d.). Retrieved May 19, 2021, from https://www.researchgate.net/figure/Semantics-of-the-Weibull-distribution-the-bathtub-curve_fig4_305334045

- Servo Motor Tester Circuit Diagram using IC 555. (n.d.). Retrieved May 29, 2021, from <https://circuitdigest.com/electronic-circuits/servo-motor-tester-circuit>
- Shrikhande, S. v., Patil, V. K., Ganesh, G., Biswas, B. B., & Patil, R. K. (2010). Hardware reliability prediction of computer based safety systems of Indian nuclear plants. *2010 2nd International Conference on Reliability, Safety and Hazard, ICRESH-2010: Risk-Based Technology and Physics-of-Failure Methods*, 127–132. <https://doi.org/10.1109/ICRESH.2010.5779529>
- Smart Innovations in Communication and Computational Sciences: Proceedings ... - Google Books. (n.d.). Retrieved June 30, 2021, from https://books.google.com.cy/books?id=kPh6DwAAQBAJ&pg=PA184&dq=arduino+failure+rate&hl=en&sa=X&ved=2ahUKEwi0rqW_u73xAhWHraQKHS_ODP4QuwUwBHoECAYQBg#v=onepage&q=arduino%20failure%20rate&f=false
- Snake Robot : 7 Steps (with Pictures) - Instructables. (n.d.). Retrieved May 10, 2021, from <https://www.instructables.com/Snake-Robot-1/>
- Snake Robots Crawl to the Rescue, Part 1 - ASME. (n.d.). Retrieved May 21, 2021, from <https://www.asme.org/topics-resources/content/snake-robots-crawl-rescue-part-1>
- Thakker, R., Kamat, A., Bharambe, S., Chiddarwar, S., & Bhurchandi, K. M. (2014a). ReBiS - Reconfigurable Bipedal Snake robot. *IEEE International Conference on Intelligent Robots and Systems*, 309–314. Institute of Electrical and Electronics Engineers Inc. <https://doi.org/10.1109/IROS.2014.6942577>
- Thakker, R., Kamat, A., Bharambe, S., Chiddarwar, S., & Bhurchandi, K. M. (2014b). ReBiS - Reconfigurable Bipedal Snake robot. *IEEE International Conference on Intelligent Robots and Systems*, 309–314. Institute of Electrical and Electronics Engineers Inc. <https://doi.org/10.1109/IROS.2014.6942577>
- Use an IR Remote Transmitter and Receiver with Arduino - Arduino Project Hub. (n.d.). Retrieved May 20, 2021, from <https://create.arduino.cc/projecthub/electropeak/use-an-ir-remote-transmitter-and-receiver-with-arduino-1e6bc8>
- What is a Servo Motor and How it Works? | RealPars. (n.d.). Retrieved May 21, 2021, from <https://realpars.com/servo-motor/>
- Wright, C., Johnson, A., Peck, A., Mccord, Z., Naaktgeboren, A., Gianfortoni, P., ... Choset, H. (n.d.). *Design of a Modular Snake Robot*.
- Zhaoxin - Karakoy Elektronik. (n.d.). Retrieved May 24, 2021, from https://karakoyelektronik.com/112_zhaoxin
- Zhou, T., Ma, S., Yu, D., Li, M., & Hang, T. (2020). Development of reliable, high performance wlcsp for bsi cmos image sensor for automotive application. *Sensors (Switzerland)*, 20(15), 1–16. <https://doi.org/10.3390/s20154077>

APPENDIX A: Electronic Media



Eastern Mediterranean University
For Your International Career

Snake Robot

Shah Mohammed Isfar, Abulirhaman Saber Ali Mahfoudh, Muratcan Yüce
Department of Mechanical and Mechatronics Engineering
Eastern Mediterranean University



TEAM FER-DE-LANCE
"Knowledge is Power"

OVERVIEW AND AIM OF THE PROJECT

- The following project describes the design, integration, reliability analysis, manufacturing plan and prototype testing plan of a low-cost snake robot.
- The snake robot will be programmed to scale various environments with the aid of servo motors integrated within each module via 3D printed C-brackets.
- The focus of this project is to integrate existing technologies, components and method to design a snake robot that can be used to probe and collect data from various environments.

COST ANALYSIS

The cost of the servo motors is the highest when compared to the cost of other electronic components. This is followed by the cost of the 3D printing filament which will be used to generate the structural components of the snake robot, comprising of the head and tailcap as well as the middle joints.

Category	Percentage
Cost of components	44%
Cost of shipping	20%
3D printing	32%
Tax	4%

TECHNICAL SPECIFICATIONS

Actuation type	12 Tower Pro MG996R Servo motors in parallel configuration
Control unit	Arduino Uno microcontroller
Remote control system	Infrared
Joint type	Orthogonally articulated 3D printed PLA+ C-brackets
Locomotion modes	Sidewinding, rectilinear, serpentine and rolling.
Operating environment	Terrestrial constrained environments. Naval sheltered.
Monitoring devices	CMOS OV7670 Camera module
Power unit	External variable power supply

DESIGN

The snake robot design was inspired by Will Donaldson's online robotics project with the Arduino as well as various ongoing robotics research projects such as the Carnegie Mellon University Snakebot.



General Assembly of Snake Robot

STRUCTURAL ANALYSIS

The structural analysis of the joints have been done using ANSYS. Various qualities like total deformation and thermal effects were analyzed to improve future structure designs.

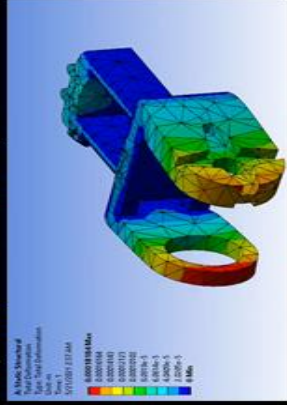

Servo Segment Total Deformation analysis

PROTOTYPES



S8001 – X-Proto. Built for experimental purposes and studying various snake locomotion.

S8002 – "Marauder" Light Duty. Built for surveying and data acquisition in mid environments.

S8003 – "Dragon" Heavy Duty. Built for applications in rough environments. Equipped with high torque RC racing servos for maximum performance.

Electronics architecture

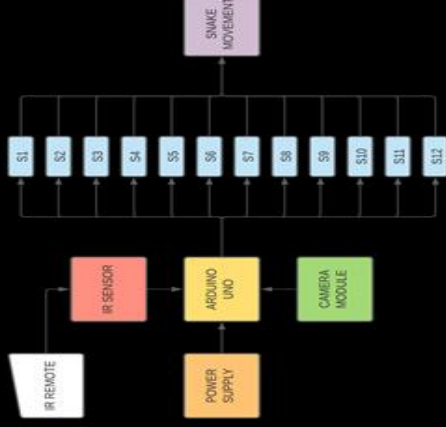

For more information, visit our website at <https://team-fer-de-lance.wixsite.com/teamferdelance>

APPENDIX B: Standards

ISO 128-21: Technical Drawings — General principles of presentation: art 21 Preparation of lines by CAD systems.

ISO 13482:2014: Robots and robotic devices — Safety requirements for personal care robots.

ISO/DIS 10218-2 ROBOTICS — Safety requirements for robot systems in an industrial environment — PART 2: Robot systems, robot applications and robot cells integration.

ISO 8373:2012 Robots and robotic devices — defines terms used in relation with robots and robotic devices operating in both industrial and non-industrial environments.

ISO/IEC DIS 23510: Information technology — 3D Printing and scanning — Framework for additive manufacturing service platform (AMSP).

ISO/IEC/IEEE FDIS 29119-4: Software and systems engineering — software testing — PART 4: Test techniques

ISO/IEC/IEEE 29119-4:2015: Software and systems engineering — Software testing — PART 4: Test techniques

ISO/WD 5363: Robotics — Test methods for Walking RACA Robot

ISO 9283:1998: Manipulating industrial robots — Performance criteria and related test methods

ISO 9787:2013: Robots and robotic devices — Coordinate systems and motion nomenclatures

ASTM D495-14: Standard Test Method for High-Voltage, Low-Current, Dry Arc Resistance of Solid Electrical Insulation

ASTM D150-18: Standard Test Methods for AC Loss Characteristics and Permittivity
(Dielectric Constant) of Solid Electrical Insulation

ASTM D2303-20e1: Standard Test Methods for Liquid-Contaminant, Inclined-Plane
Tracking and Erosion of Insulating Materials

IPC-MF-150: Metal Foil for Printed Wiring Applications.

APPENDIX C: Constraints

<u>Constraints</u>	<u>Yes</u>	<u>No</u>
Economic	X	
Sustainable	X	
Manufacturable	X	
Environment friendly	X	
Safety	X	
Ethical	X	

- **Economic** – Efficient use of the budget and availability of components and parts.
- **Sustainability** – A well-defined life span under the assumed normal operation conditions. Consideration of environmental factors in design. Reliability and durability of the products supposed function.
- **Manufacturability** – Easily manufactured with respect to cost, availability, and environment.
- **Environmental factors** – Ensuring the definitive version of the snake robot is environment friendly in ways one can easily dispose of components and casings without causing harm to the surroundings.
- **Safety** – Creating a user-friendly design which poses no risk of danger or harm to the operator, whether it involves electrical components like the battery or the external dimensions of the device.

- **Ethical** – Designs without considering safety and health of workers, consumers and/or the public.































APPENDIX D: Project Plan

Meeting Date	Time Duration	Meeting Summary
09.03.2021	3 P.M. – 3.30 P.M.	<ul style="list-style-type: none"> • Team members met with the Supervisor to finalize the number of members of the group. • Ideas and motivations about project is expressed.
10.03.2021	2.30 P.M. – 3.30 P.M.	<ul style="list-style-type: none"> • Cost analysis of Snake Robot is discussed and started to prepare • Tasks are assigned to all members
18.03.2021	6 P.M. – 9 P.M.	<ul style="list-style-type: none"> • Researching the project in detail and getting more information about the project. • Different ideas about software and design is shared. Some improvements have been made.
23.03.2021	8.30 A.M. – 10.30 A.M.	<ul style="list-style-type: none"> • Chapters 1 and 2 checked. • Before starting chapter 3, what calculations to do and chapter 3's format are determined.
14.04.2021	9 A.M. – 1 P.M.	<ul style="list-style-type: none"> • Chapter 3 is reviewed • Chapter 4 tasks are shared. • Design of the project is discussed and decided to start
18.04.2021	8.30 A.M. – 11 A.M.	<ul style="list-style-type: none"> • Chapter 4 is reviewed • Software improvements are discussed. • Chapter 5 and Appendices tasks are shared.
12.05.2021	8.30 A.M. – 10 A.M.	<ul style="list-style-type: none"> • Chapter 5 is reviewed.

		<ul style="list-style-type: none">• Editing and formatting type is selected.
19.05.2021	7 P.M. – 10 P.M.	<ul style="list-style-type: none">• Appendices are checked.
26.05.2021	8.30 A.M.-9.30 A.M.	<ul style="list-style-type: none">• All report has been reviewed. Some updates and developments are done.

Gantt chart



		Task Name	Duration	Start	Finish
1		Snake Robot	321 days	March 19, 2021	February 02, 2022
2		1. Conceptual Design	14 days	March 19, 2021	April 01, 2021
3		1.1 Define Mission of Snake Robot	11 days	March 19, 2021	March 29, 2021
4		1.2 Development of Snake Robot Design	8 days	March 19, 2021	March 26, 2021
5		1.3 Development of Snake Robot Concepts	11 days	March 19, 2021	March 29, 2021
6		1.3.1 Design Joints	11 days	March 19, 2021	March 29, 2021
7		1.3.2 Design Location of Electronic Components	3 days	March 27, 2021	March 29, 2021
8		1.4 Selection of Suitable Concept	4 days	March 29, 2021	April 01, 2021
9		2. Preliminary Design of Snake Robot	11 days	April 03, 2021	April 13, 2021
10		2.1 Developing Design of Selected Concept	6 days	April 03, 2021	April 08, 2021
11		2.2 Discussion and Draft of Report	6 days	April 08, 2021	April 13, 2021
12		3. Detail Design of Snake Robot	64 days	April 15, 2021	June 17, 2021
13		3.1 Completion of Selection	2 days	April 15, 2021	April 16, 2021
14		3.2 Completion of CAD Models	6 days	April 16, 2021	April 21, 2021
15		3.3 Completion of Detail Drawings	11 days	April 16, 2021	April 26, 2021
16		3.4 Completion of Snake Robot Design	6 days	May 01, 2021	May 06, 2021
17		3.5 Completion of Manufacturing Plan	17 days	April 16, 2021	May 02, 2021
18		3.6 Completion of Testing Plan	16 days	May 02, 2021	May 17, 2021
19		3.7 Documentation Update	32 days	May 17, 2021	June 17, 2021
20		4. Prototype Development	82 days	August 30, 2021	November 19, 2021
21		4.1 Procurement of Components	21 days	August 30, 2021	September 19, 2021
22		4.1.1 Servo Motor	21 days	August 30, 2021	September 19, 2021
23		4.1.2 Electronic Components	7 days	August 30, 2021	September 05, 2021
24		4.1.3 Miscellaneous Materials	11 days	August 30, 2021	September 09, 2021
25		4.1.4 3D Printer Filament	6 days	August 30, 2021	September 04, 2021
26		4.2 Manufacturing of 3D Parts	26 days	September 04, 2021	September 29, 2021
27		4.3 Assembly of Snake Robot	11 days	October 10, 2021	October 20, 2021
28		4.4 Plugging Electronic Components and Wiring	15 days	November 05, 2021	November 19, 2021
29		5. Design Validation and Verification & Testing	15 days	November 19, 2021	December 03, 2021
30		5.1 Testing of Servo Motors	11 days	November 19, 2021	November 29, 2021
31		5.2 Testing of IR Remote Controller	2 days	November 19, 2021	November 20, 2021
32		5.3 Product Validation and Verification	2 days	November 30, 2021	December 01, 2021
33		5.4 Result Comparison	3 days	December 01, 2021	December 03, 2021
34		6. Normal Operation	62 days	December 03, 2021	February 02, 2022
35		6.1 Data Acquisition	26 days	December 03, 2021	December 28, 2021
36		6.2 Documentation Updates	62 days	December 03, 2021	February 02, 2022
37		6.3 Promotional Materials Updates	9 days	January 25, 2022	February 02, 2022

APPENDIX E: Engineering Drawings

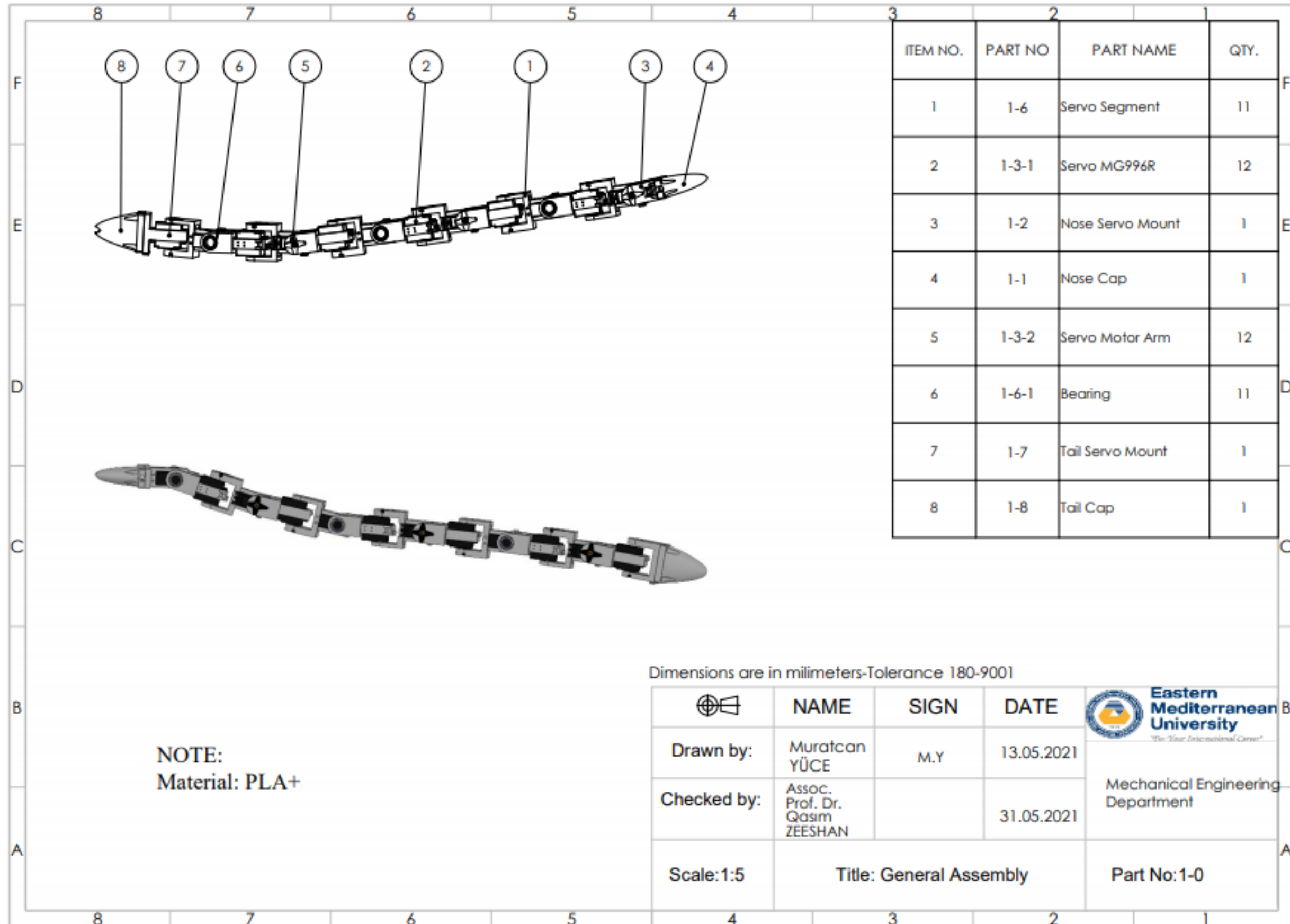

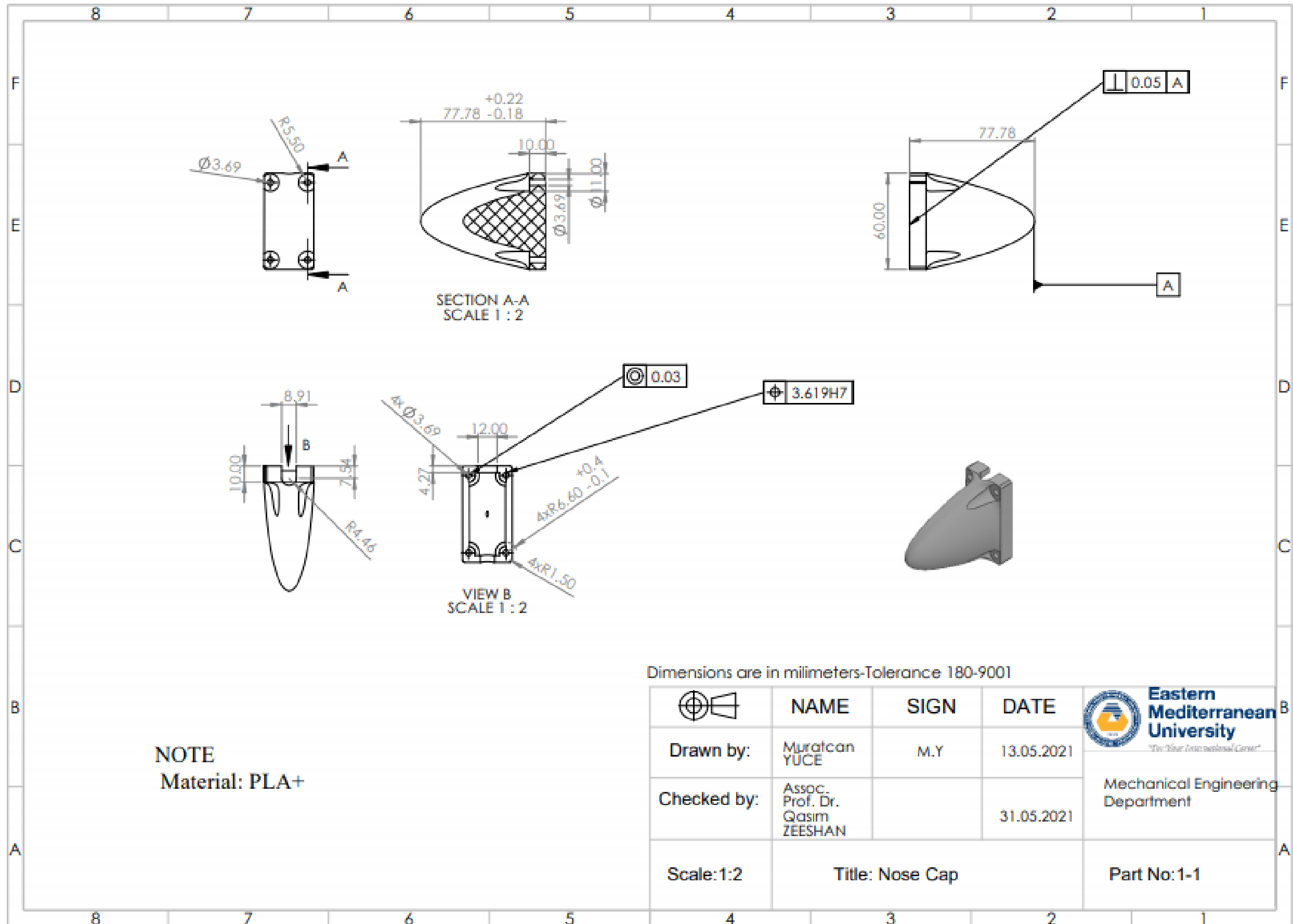

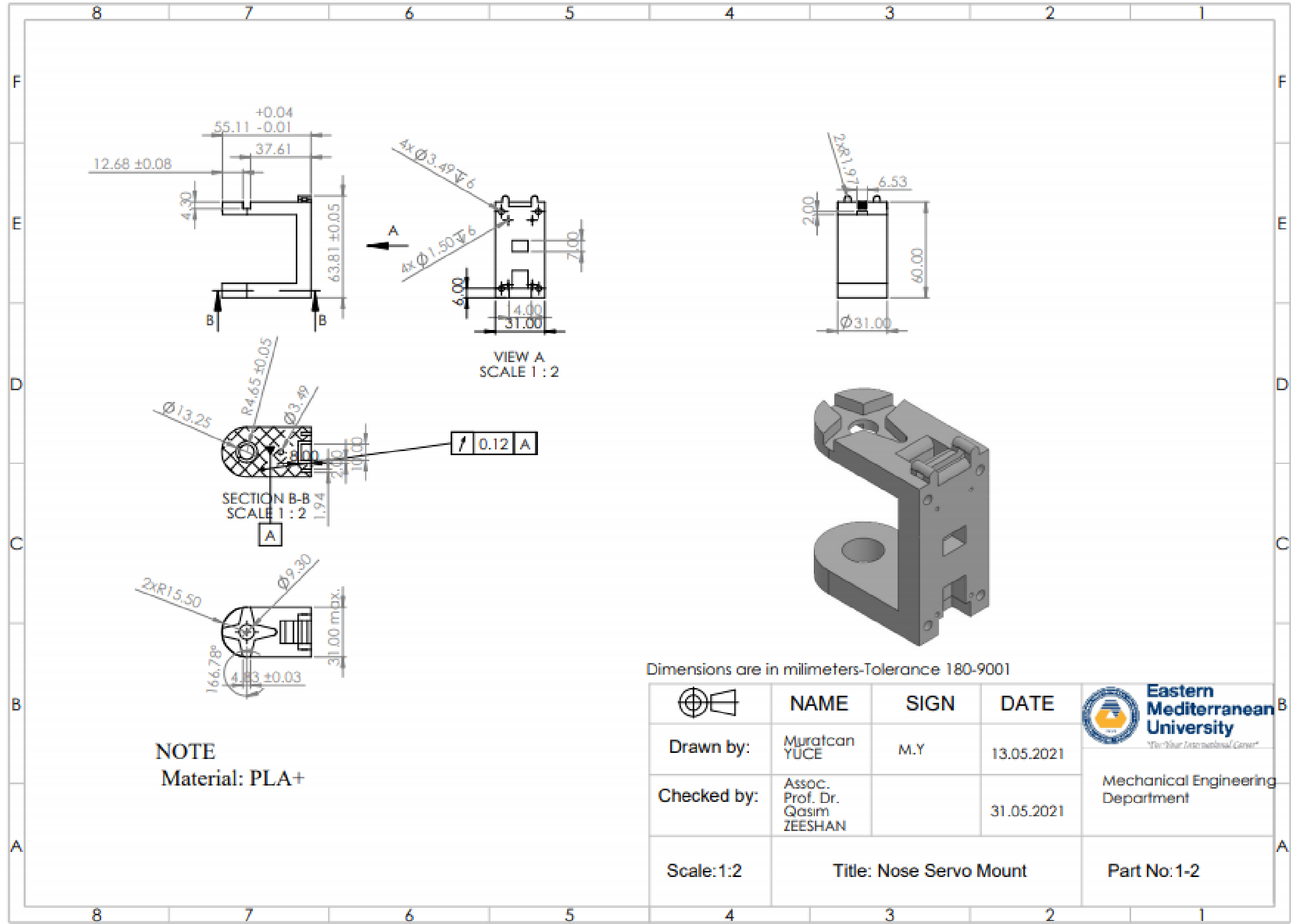

NOTE
Material: PLA+

Dimensions are in millimeters-Tolerance 180-9001

	NAME	SIGN	DATE	Eastern Mediterranean University <i>"For Your International Career"</i>
Drawn by:	Muratcan YUCE	M.Y	13.05.2021	
Checked by:	Assoc. Prof. Dr. Qasim ZEESHAN		31.05.2021	
Scale: 1:2	Title: Nose Servo Mount		Part No: 1-2	

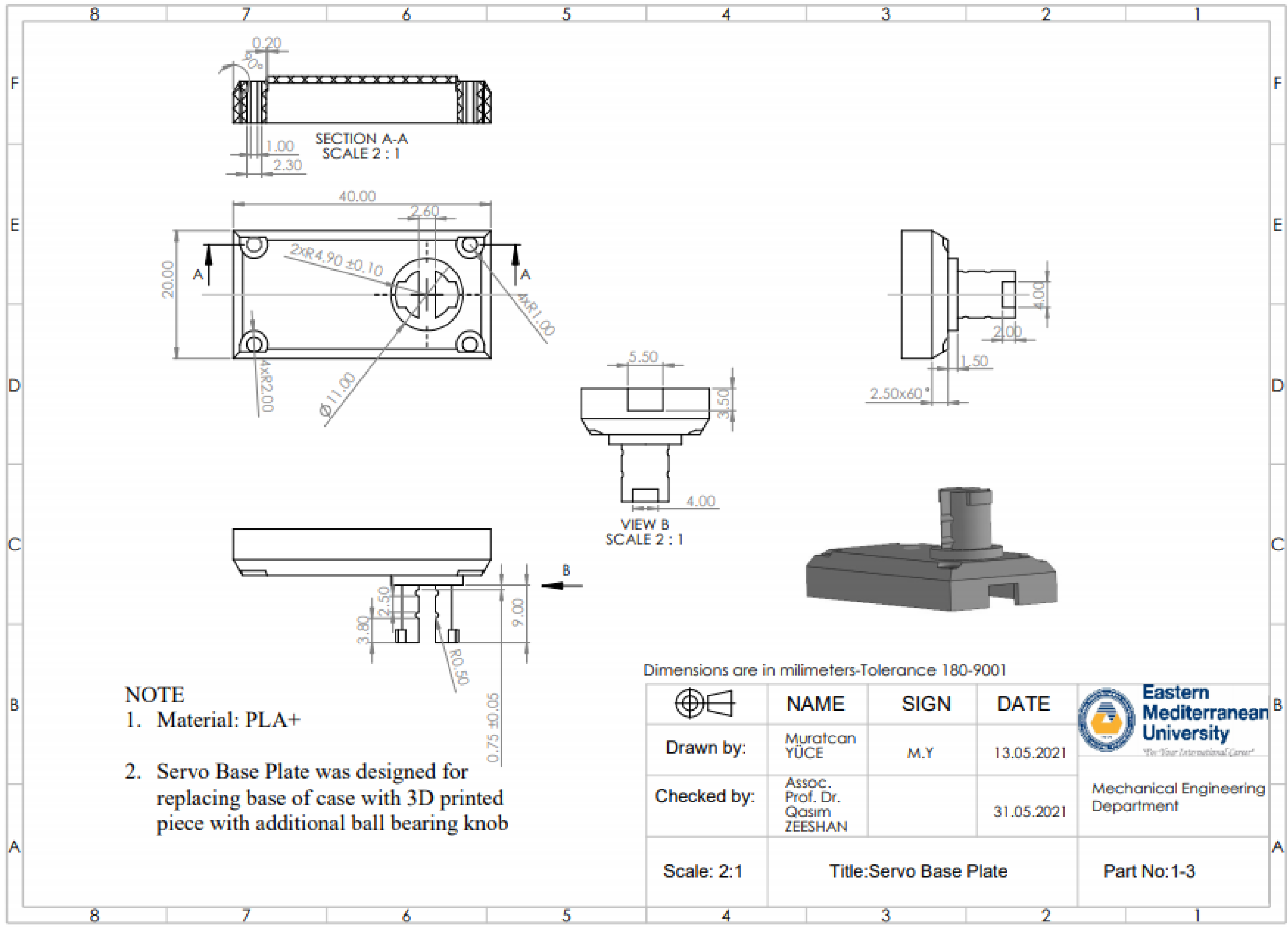

- NOTE**
1. Material: PLA+
 2. Servo Base Plate was designed for replacing base of case with 3D printed piece with additional ball bearing knob

Dimensions are in millimeters-Tolerance 180-9001

Symbol	NAME	SIGN	DATE	 Eastern Mediterranean University <small>"Be Your International Career"</small>
Drawn by:	Muratcan YÜCE	M.Y	13.05.2021	
Checked by:	Assoc. Prof. Dr. Qasim ZEESHAN		31.05.2021	Mechanical Engineering Department
Scale: 2:1	Title: Servo Base Plate		Part No: 1-3	

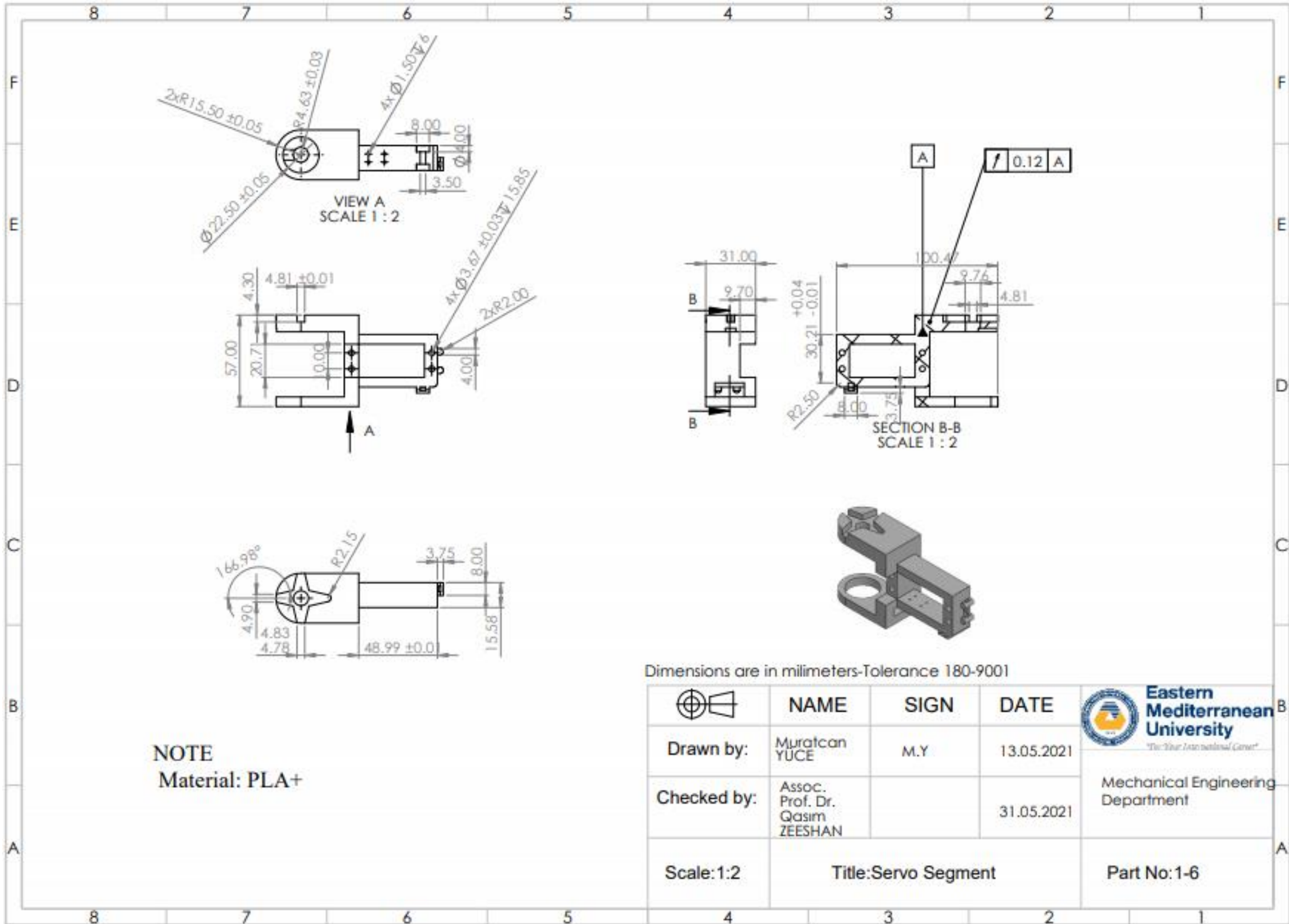

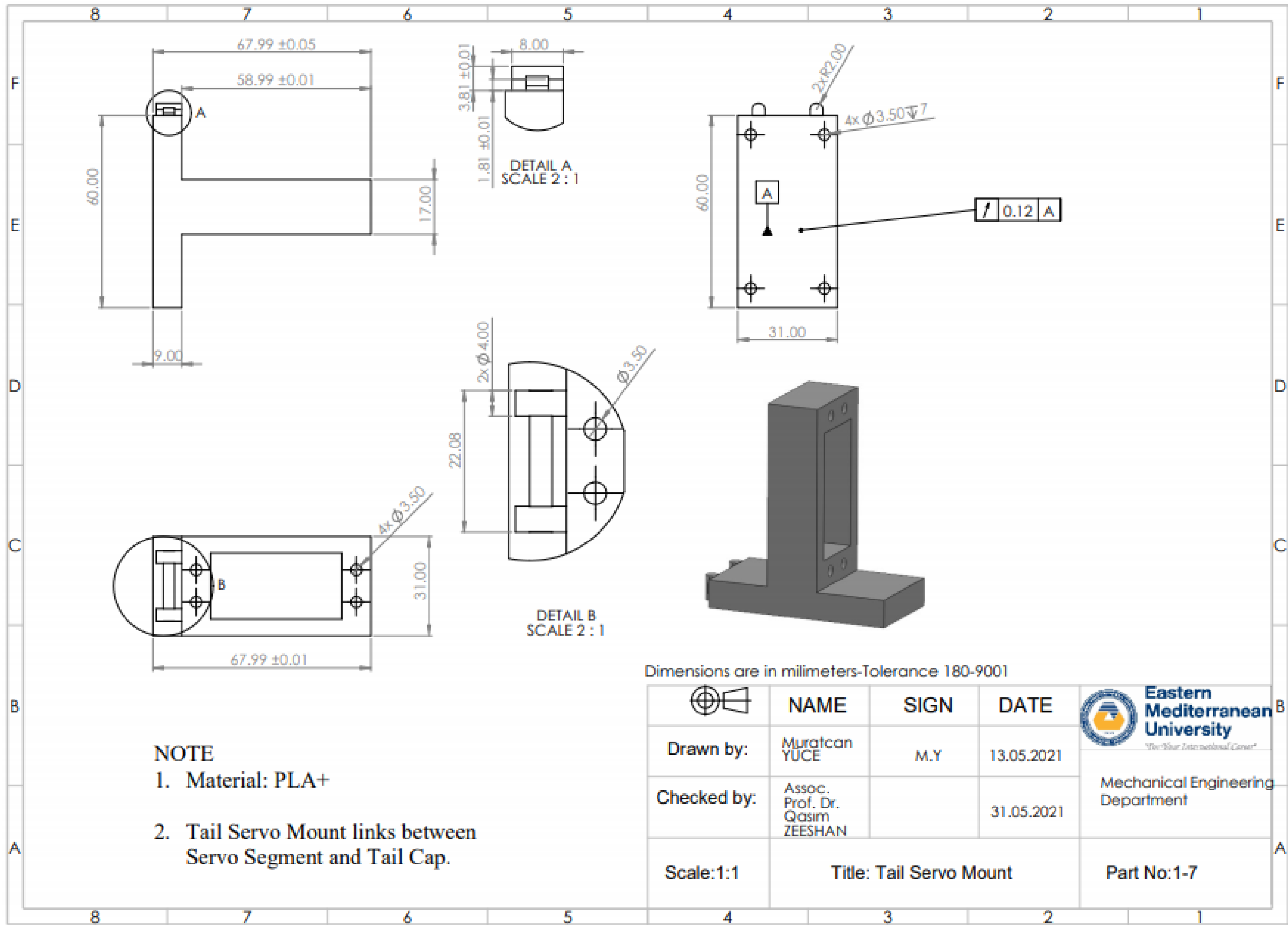

NOTE

1. Material: PLA+
2. Tail Servo Mount links between Servo Segment and Tail Cap.

Dimensions are in millimeters-Tolerance 180-9001

	NAME	SIGN	DATE	Eastern Mediterranean University <small>"Your Future. Our Passion. Our Career"</small>
Drawn by:	Muratcan YUCE	M.Y	13.05.2021	
Checked by:	Assoc. Prof. Dr. Qasim ZEESHAN		31.05.2021	
Scale:1:1	Title: Tail Servo Mount		Part No:1-7	

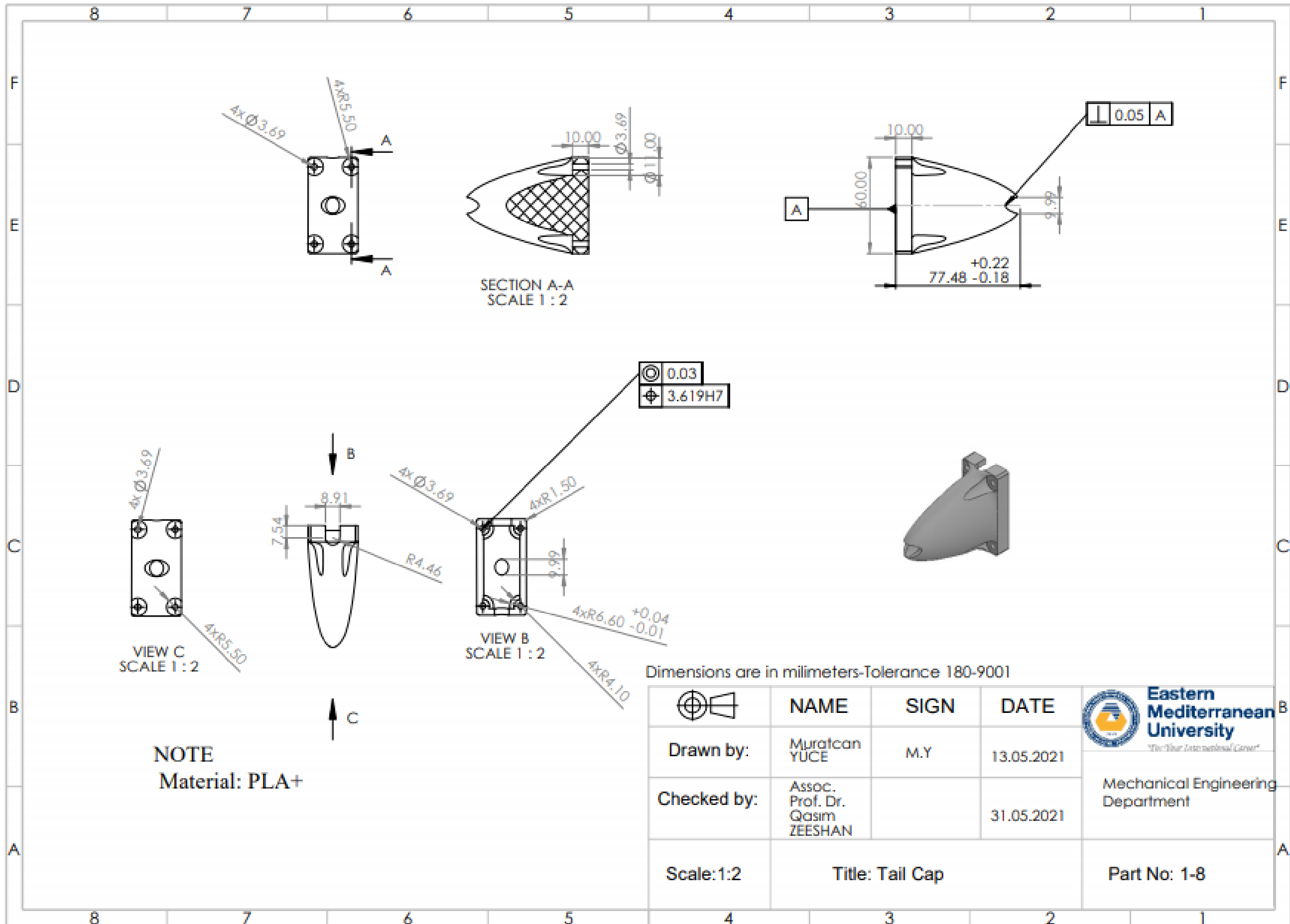

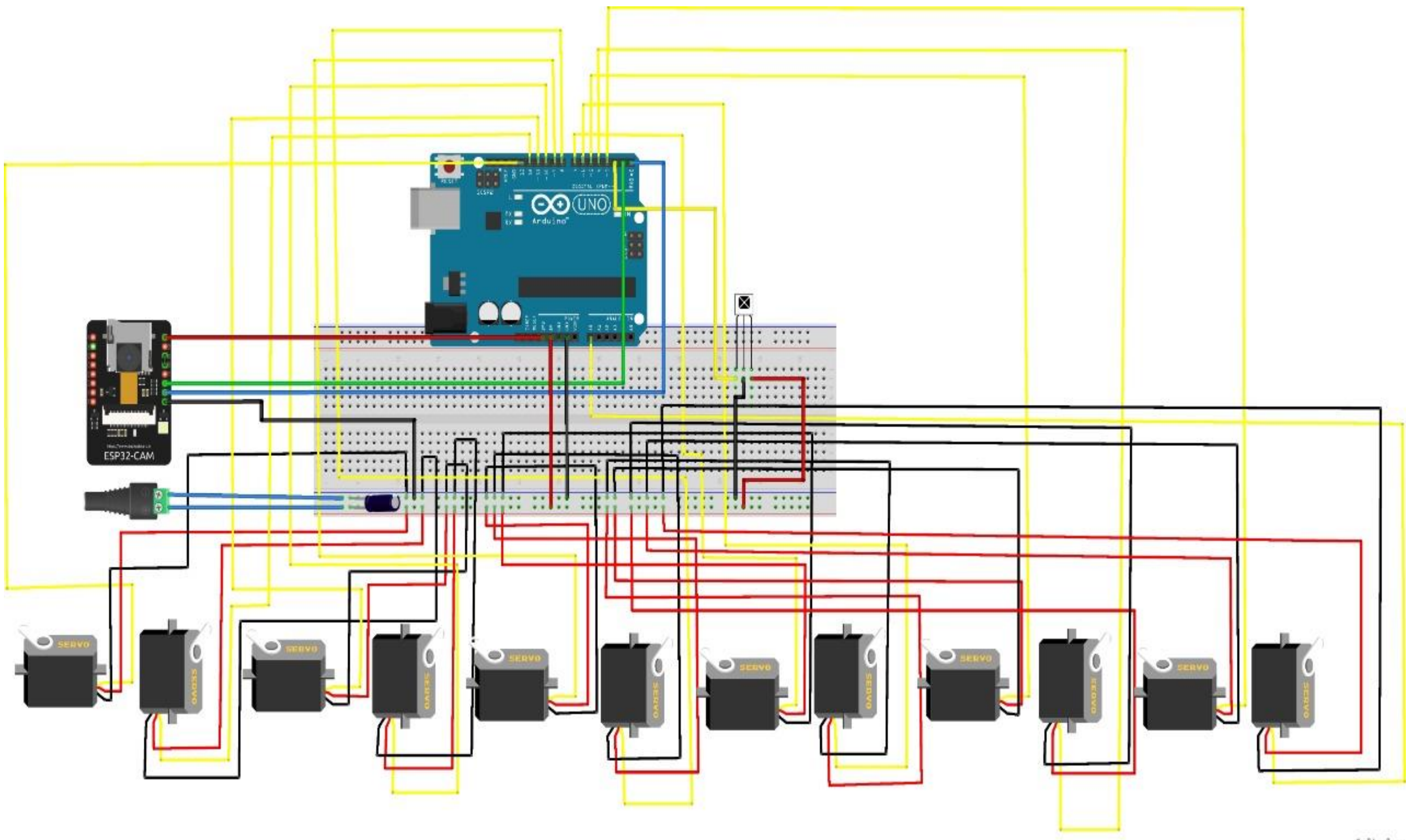

fritzing

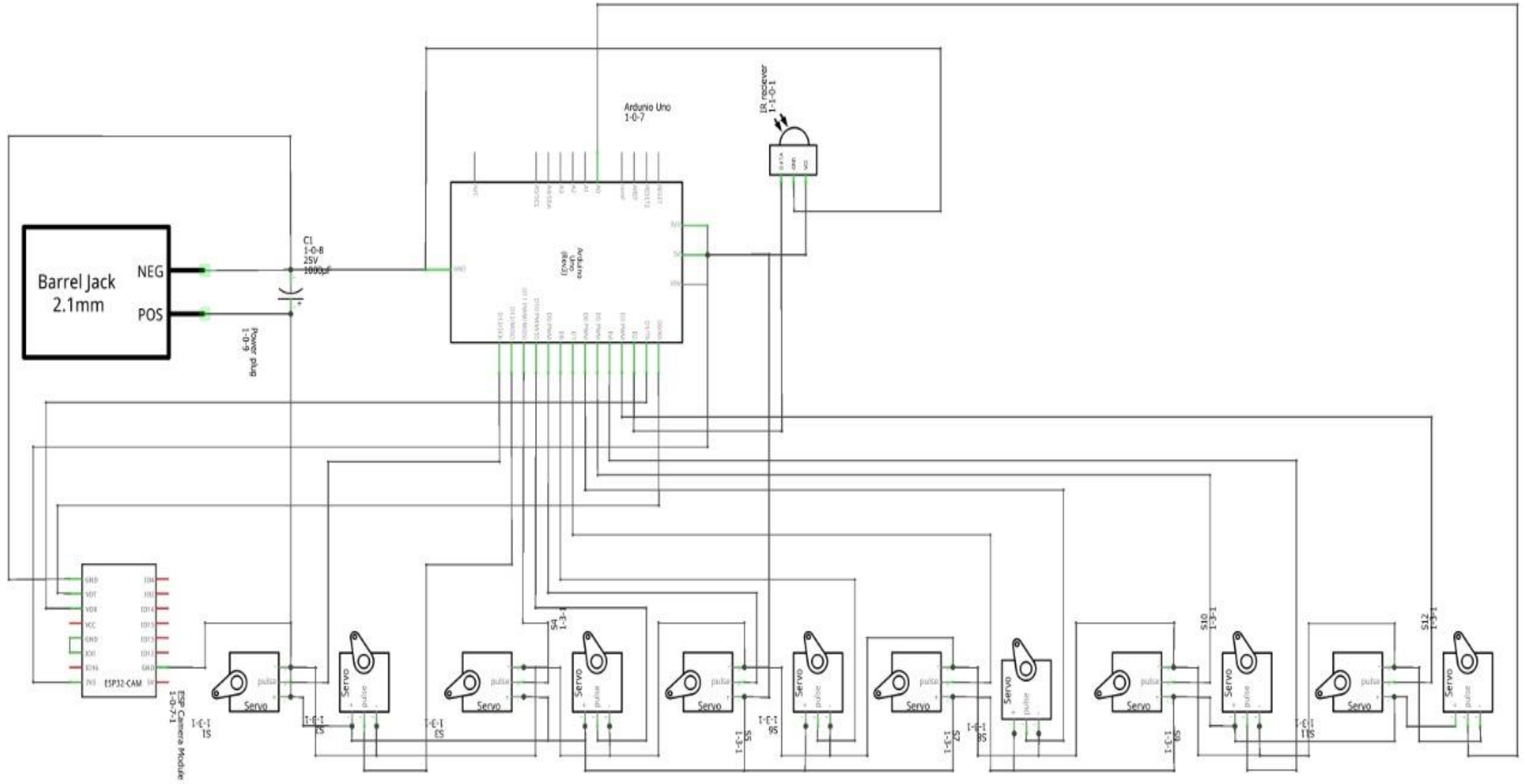

APPENDIX F: Component specifications

Bearing No. 608 2RS

Specifications

(Boundary dimensions ...etc)

d(mm)	8
D(mm)	22
B(mm)	7
r(min.)(mm)	0.3
Basic load ratings : Cr(kN)	4.10
Basic load ratings : C0r(kN)	1.35
Fatigue load limit : Cu(kN)	0.060
factor : f0(l)	12.4
Limiting speeds(Grease lub.)(min-1)	23000
Limiting speeds(Oil lub.)(min-1)	-

Mounting dimensions

da(min.)(mm)	10
Da(max.)(mm)	20
ra(max.)(mm)	0.3
Refer.	
(Refer.)Mass(g)	12

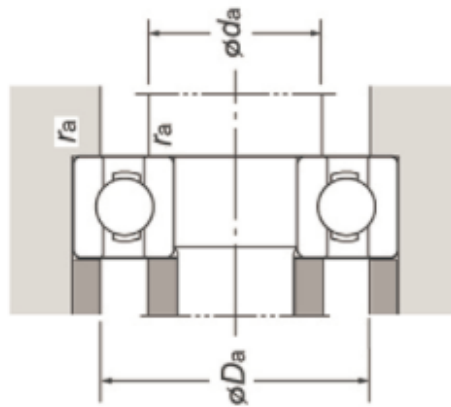
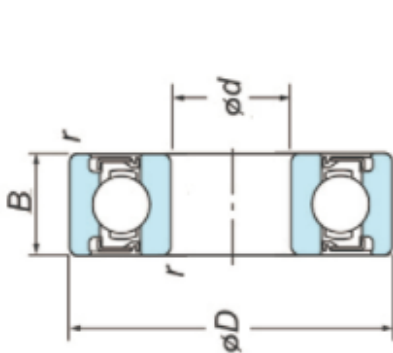

JTEKT CORPORATION

2021/05/25

MG996R High Torque Metal Gear Dual Ball Bearing Servo

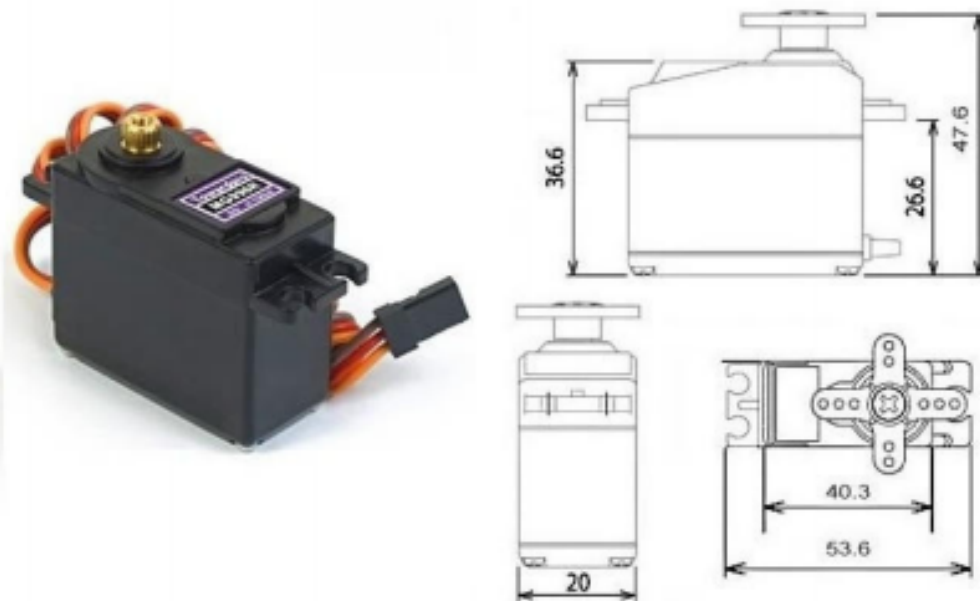

This High-Torque MG996R Digital Servo features metal gearing resulting in extra high 10kg stalling torque in a tiny package. The MG996R is essentially an upgraded version of the famous MG995 servo, and features upgraded shock-proofing and a redesigned PCB and IC control system that make it much more accurate than its predecessor. The gearing and motor have also been upgraded to improve dead bandwith and centering. The unit comes complete with 30cm wire and 3 pin 'S' type female header connector that fits most receivers, including Futaba, JR, GWS, Cirrus, Blue Bird, Blue Arrow, Corona, Berg, Spektrum and Hitec.

This high-torque standard servo can rotate approximately 120 degrees (60 in each direction). You can use any servo code, hardware or library to control these servos, so it's great for beginners who want to make stuff move without building a motor controller with feedback & gear box, especially since it will fit in small places. The MG996R Metal Gear Servo also comes with a selection of arms and hardware to get you set up nice and fast!

Specifications

- Weight: 55 g
- Dimension: 40.7 x 19.7 x 42.9 mm approx.
- Stall torque: 9.4 kgf·cm (4.8 V), 11 kgf·cm (6 V)
- Operating speed: 0.17 s/60° (4.8 V), 0.14 s/60° (6 V)

- Operating voltage: 4.8 V a 7.2 V
- Running Current 500 mA – 900 mA (6V)
- Stall Current 2.5 A (6V)
- Dead band width: 5 μ s
- Stable and shock proof double ball bearing design
- Temperature range: 0 $^{\circ}$ C – 55 $^{\circ}$ C

PWM=Orange (\square)
 Vcc = Red (+)
 Ground=Brown (-)

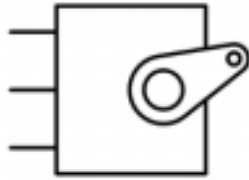
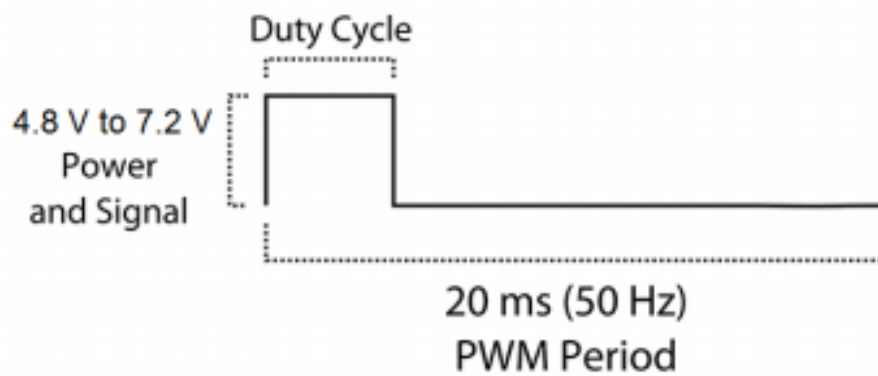
Technical Specification



EAGLE files: [arduino-duemilanove-uno-design.zip](#) Schematic: [arduino-uno-schematic.pdf](#)

Summary

Microcontroller	ATmega328
Operating Voltage	5V
Input Voltage (recommended)	7-12V
Input Voltage (limits)	6-20V
Digital I/O Pins	14 (of which 6 provide PWM output)
Analog Input Pins	6
DC Current per I/O Pin	40 mA
DC Current for 3.3V Pin	50 mA
Flash Memory	32 KB of which 0.5 KB used by bootloader
SRAM	2 KB
EEPROM	1 KB
Clock Speed	16 MHz

the board

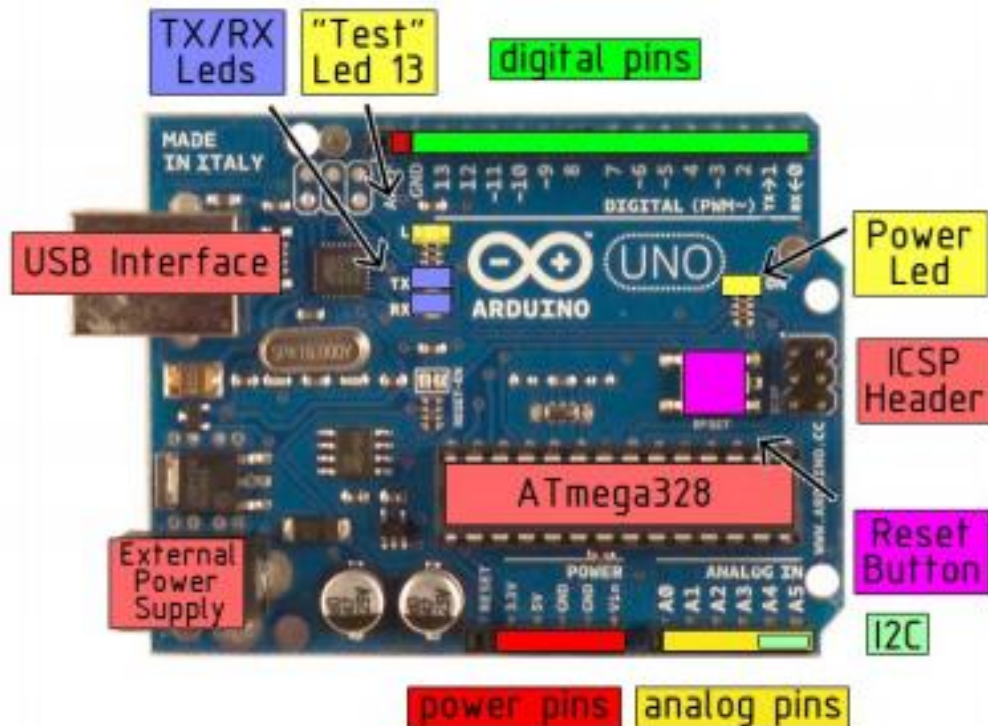

Reflective Optical Sensor with Transistor Output

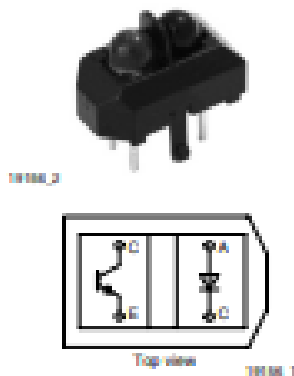

FEATURES

- Package type: leaded
- Detector type: phototransistor
- Dimensions (L x W x H in mm): 10.2 x 5.8 x 7
- Peak operating distance: 2.5 mm
- Operating range within > 20 % relative collector current: 0.2 mm to 15 mm
- Typical output current under test: $I_C = 1$ mA
- Daylight blocking filter
- Emitter wavelength: 950 nm
- Lead (Pb)-free soldering released
- Compliant to RoHS directive 2002/95/EC and in accordance to WEEE 2002/96/EC

RoHS
COMPLIANT

DESCRIPTION

The TCRT5000 and TCRT5000L are reflective sensors which include an infrared emitter and phototransistor in a leaded package which blocks visible light. The package includes two mounting clips. TCRT5000L is the long lead version.

APPLICATIONS

- Position sensor for shaft encoder
- Detection of reflective material such as paper, IBM cards, magnetic tapes etc.
- Limit switch for mechanical motions in VCR
- General purpose - wherever the space is limited

PRODUCT SUMMARY

PART NUMBER	DISTANCE FOR MAXIMUM CTR _{max} ⁽¹⁾ (mm)	DISTANCE RANGE FOR RELATIVE I _{col} > 20 % (mm)	TYPICAL OUTPUT CURRENT UNDER TEST P ⁽²⁾ (mA)	DAYLIGHT BLOCKING FILTER INTEGRATED
TCRT5000	2.5	0.2 to 15	1	Yes
TCRT5000L	2.5	0.2 to 15	1	Yes

Notes

⁽¹⁾ CTR: current transfer ratio, I_{col}/I_e

⁽²⁾ Conditions like in table basic characteristics/sensors

ORDERING INFORMATION

ORDERING CODE	PACKAGING	VOLUME ⁽¹⁾	REMARKS
TCRT5000	Tube	MOC: 4500 pcs, 50 pcs/tube	3.5 mm lead length
TCRT5000L	Tube	MOC: 2400 pcs, 48 pcs/tube	15 mm lead length

Note

⁽¹⁾ MOC: minimum order quantity

ABSOLUTE MAXIMUM RATINGS ⁽¹⁾

PARAMETER	TEST CONDITION	SYMBOL	VALUE	UNIT
INPUT (EMITTER)				
Reverse voltage		V_R	5	V
Forward current		I_F	60	mA
Forward surge current	$t_p \leq 10 \mu s$	I_{FSM}	3	A
Power dissipation	$T_{amb} \leq 25^\circ C$	P_D	100	mW
Junction temperature		T_J	100	$^\circ C$

TCRT5000, TCRT5000L

Vishay Semiconductors

Reflective Optical Sensor with Transistor Output



ABSOLUTE MAXIMUM RATINGS ⁽¹⁾				
PARAMETER	TEST CONDITION	SYMBOL	VALUE	UNIT
OUTPUT (DETECTOR)				
Collector emitter voltage		V_{CEO}	70	V
Emitter collector voltage		V_{ECO}	5	V
Collector current		I_C	100	mA
Power dissipation	$T_{amb} \leq 55^\circ\text{C}$	P_V	100	mW
Junction temperature		T_J	100	$^\circ\text{C}$
SENSOR				
Total power dissipation	$T_{amb} \leq 25^\circ\text{C}$	P_{tot}	200	mW
Ambient temperature range		T_{amb}	- 25 to + 85	$^\circ\text{C}$
Storage temperature range		T_{stg}	- 25 to + 100	$^\circ\text{C}$
Soldering temperature	2 mm from case, $t \leq 10$ s	T_{sd}	260	$^\circ\text{C}$

Note

⁽¹⁾ $T_{amb} = 25^\circ\text{C}$, unless otherwise specified

ABSOLUTE MAXIMUM RATINGS

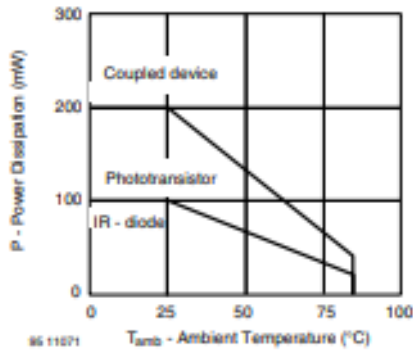

Fig. 1 - Power Dissipation Limit vs. Ambient Temperature

BASIC CHARACTERISTICS ⁽¹⁾						
PARAMETER	TEST CONDITION	SYMBOL	MIN.	TYP.	MAX.	UNIT
INPUT (EMITTER)						
Forward voltage	$I_F = 60$ mA	V_F		1.25	1.5	V
Junction capacitance	$V_R = 0$ V, $f = 1$ MHz	C_j		17		pF
Radiant intensity	$I_F = 60$ mA, $t_p = 20$ ms	I_e			21	mW/sr
Peak wavelength	$I_F = 100$ mA	λ_p	940			nm
Virtual source diameter	Method: 63 % encircled energy	d		2.1		mm
OUTPUT (DETECTOR)						
Collector emitter voltage	$I_C = 1$ mA	V_{CEO}	70			V
Emitter collector voltage	$I_e = 100$ μA	V_{ECO}	7			V
Collector dark current	$V_{CE} = 20$ V, $I_F = 0$ A, $E = 0$ lx	I_{CDO}		10	200	nA
SENSOR						
Collector current	$V_{CE} = 5$ V, $I_F = 10$ mA, $D = 12$ mm	I_C ⁽²⁾ ⁽³⁾	0.5	1	2.1	mA
Collector emitter saturation voltage	$I_F = 10$ mA, $I_C = 0.1$ mA, $D = 12$ mm	V_{CEsat} ⁽²⁾ ⁽³⁾			0.4	V

Note

⁽¹⁾ $T_{amb} = 25^\circ\text{C}$, unless otherwise specified

⁽²⁾ See figure 3

⁽³⁾ Test surface: mirror (Mfr. Spindler a. Hoyer, Part No. 340005)

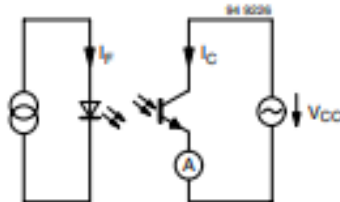

Fig. 2 - Test Circuit

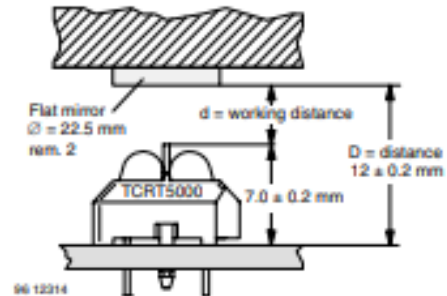
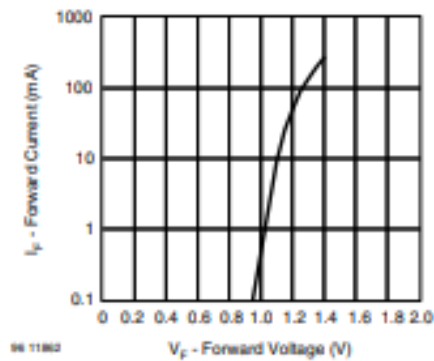
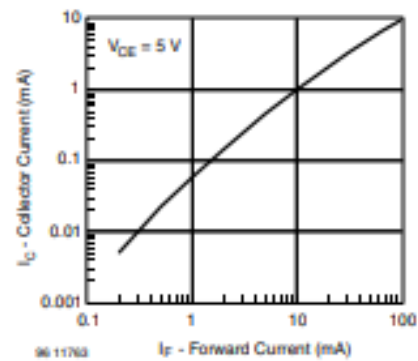

Fig. 3 - Test Circuit

BASIC CHARACTERISTICS
 $T_{amb} = 25\text{ }^{\circ}\text{C}$, unless otherwise specified

96 11762

Fig. 4 - Forward Current vs. Forward Voltage



96 11763

Fig. 6 - Collector Current vs. Forward Current

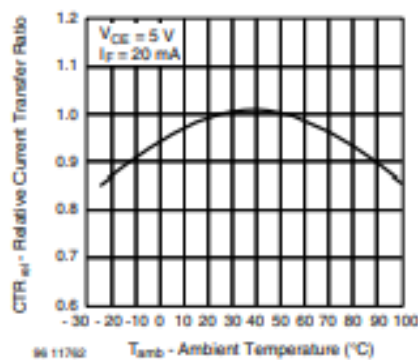

96 11762

Fig. 5 - Relative Current Transfer Ratio vs. Ambient Temperature

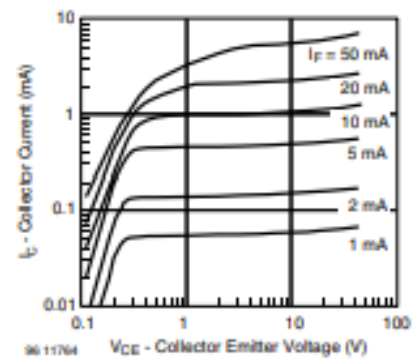

96 11764

Fig. 7 - Collector Emitter Saturation Voltage vs. Collector Current

2 Features

- Optical size 1/6 inch
- Resolution 640x480 VGA
- Onboard regulator, only single 3.3V supply needed
- Standard 0.1inch (2.54mm) pin pitch header connector
- Mounted with high quality F1.8 / 6mm lens
- Output support for Raw RGB, RGB (GRB 4:2:2, RGB565/555/444), YUV (4:2:2) and YCbCr (4:2:2) formats
- High sensitivity for low-light operation
- Low operating voltage for embedded portable apps
- Standard SCCB interface compatible with I2C interface
- Supports image sizes: VGA, CIF, and any size scaling down from CIF to 40x30
- VarioPixel® method for sub-sampling
- Automatic image control functions including: Automatic
- Exposure Control (AEC), Automatic Gain Control (AGC), Automatic White Balance (AWB), Automatic
- Band Filter (ABF), and Automatic Black-Level Calibration (ABLC)
- Image quality controls including color saturation, hue, gamma, sharpness (edge enhancement), and anti-blooming
- ISP includes noise reduction and defect correction
- Supports LED and flash strobe mode
- Supports scaling
- Lens shading correction
- Flicker (50/60 Hz) auto detection
- Saturation level auto adjust (UV adjust)
- Edge enhancement level auto adjust
- De-noise level auto adjust

	Active Array Size	640 x 480
Power Supply	Digital Core	1.8VDC \pm 10%
	Analog	2.45V to 3.0V
	I/O	1.7V to 3.0V ^d
Power Requirements	Active	60 mW typical (15fps VGA YUV format)
	Standby	< 20 μ A
Temperature Range	Operation	-30°C to 70°C
	Stable Image	0°C to 50°C
	Output Formats (8-bit)	<ul style="list-style-type: none"> • YUV/YCbCr 4:2:2 • RGB565/555/444 • GRB 4:2:2 • Raw RGB Data
	Lens Size	1/6"
	Chief Ray Angle	25°
	Maximum Image Transfer Rate	30 fps for VGA
	Sensitivity	1.3 V/(Lux • sec)
	S/N Ratio	46 dB
	Dynamic Range	52 dB
	Scan Mode	Progressive
	Electronics Exposure	Up to 510:1 (for selected fps)
	Pixel Size	3.6 μ m x 3.6 μ m
	Dark Current	12 mV/s at 60°C
	Well Capacity	17 K e
	Image Area	2.36 mm x 1.76 mm
	Package Dimensions	3785 μ m x 4235 μ m

Pin No.	PIN NAME	TYPE	DESCRIPTION
1	VCC	POWER	3.3v Power supply
2	GND	Ground	Power ground
3	SCL	Input	Two-Wire Serial Interface Clock
4	SDATA	Bi-directional	Two-Wire Serial Interface Data I/O
5	VSYNC	Output	Active High: Frame Valid; indicates active frame
6	HREF	Output	Active High: Line/Data Valid; indicates active pixels
7	PCLK	Output	Pixel Clock output from sensor
8	XCLK	Input	Master Clock into Sensor
9	Dout9	Output	Pixel Data Output 9 (MSB)
10	Dout8	Output	Pixel Data Output 8
11	Dout7	Output	Pixel Data Output 7
12	Dout6	Output	Pixel Data Output 6
13	Dout5	Output	Pixel Data Output 5
14	Dout4	Output	Pixel Data Output 4
15	Dout3	Output	Pixel Data Output 3
16	Dout2	Output	Pixel Data Output 2 (LSB)

APPENDIX G: Codes

```
#include <IRremote.h>
#include <Servo.h>
// Servo Variables
Servo ServoNo1;
Servo ServoNo2;
Servo ServoNo3;
Servo ServoNo4;
Servo ServoNo5;
Servo ServoNo6;
Servo ServoNo7;
Servo ServoNo8;
Servo ServoNo9;
Servo ServoNo10;
Servo ServoNo11;
Servo ServoNo12;

const int irReceiverPin =2; //the SIG of receiver module attach to
Pin2
IRrecv irrecv(irReceiverPin); //Creates a variable of type IRrecv
decode_results results;

int Flexangle = 45;
int Offset = 0;
int Rightoffset = 10; // Right turn
int Leftoffset = -10; // left turn
float Pi = 3.14159;
float Shift = 2*Pi/6; // Phase lag between segments
float Rads; // Radians
int AmplitudeSR = 35; // Amp for serpentine motion
int AmplitudeSW = 50; // Amp for Sidewinding
int Speed = 2; // Rotation Speed
float Wavelengths = 1.5; // Length of the S shape

void setup()
{
  Serial.begin(9600); //initialize serial
  irrecv.enableIRIn(); //enable ir receiver module
  ServoNo1.attach(A0); // - Tail
  ServoNo2.attach(3); // 1
  ServoNo3.attach(4); // -
  ServoNo4.attach(5); // 1
  ServoNo5.attach(6); // -
  ServoNo6.attach(7); // 1
  ServoNo7.attach(8); // -
  ServoNo8.attach(9); // 1
  ServoNo9.attach(10); // -
  ServoNo10.attach(11); // 1
  ServoNo11.attach(12); // - ^--v
  ServoNo12.attach(13); // 1 <--> Head

  //Initialise snake in a straight line
  Straightline();
}
```

```

void loop()
{
  if (irrecv.decode(&results)) //if the ir receiver module receives
data
  {
    Serial.print("irCode HEX: "); //print"irCode HEX: "
    Serial.print(results.value, HEX); //print the value
in hexadecimal
    Serial.print(" irCode DEC: "); //print"irCode DEC: "
    Serial.print(results.value, DEC); //print the value in decimal
    irrecv.resume(); // Receive the next value
  }
  if(results.value == 16724175)//if key 1 pressed (results.value ==
key DEC code)
  { // 2 or 3 or 4
    while(results.value != 16718055 || results.value != 16743045
|| results.value != 16716015 ){

      Serpentine_motion();

      if(results.value == 16754775)//if key + pressed
(results.value == key DEC code)
      {
        for(int i=0; i<360; i++){
          Rads=i*Pi/180.0; //convert from degrees to radians
          // Turns the snake right
          ServoNo2.write(90+Rightoffset+AmplitudeSR*sin(Speed*Rads+1*Wav
elengths*Shift));
          ServoNo4.write(90+Rightoffset+AmplitudeSR*sin(Speed*Rads+2*Wav
elengths*Shift));
          ServoNo6.write(90+Rightoffset+AmplitudeSR*sin(Speed*Rads+3*Wav
elengths*Shift));
          ServoNo8.write(90+Rightoffset+AmplitudeSR*sin(Speed*Rads+4*Wav
elengths*Shift));
          ServoNo10.write(90+Rightoffset+AmplitudeSR*sin(Speed*Rads+5*Wa
velengths*Shift));
          ServoNo12.write(90+Rightoffset+AmplitudeSR*sin(Speed*Rads+6*Wa
velengths*Shift));
          delay(10);
        }
      }

      if(results.value == 16769055)//if key - pressed
(results.value == key DEC code)
      {
        for(int i=0; i<360; i++){
          Rads=i*Pi/180.0; //convert from degrees to radians
          // Turns the snake left
          ServoNo2.write(90+Leftoffset+AmplitudeSR*sin(Speed*Rads+1*Wave
lengths*Shift));
          ServoNo4.write(90+Leftoffset+AmplitudeSR*sin(Speed*Rads+2*Wave
lengths*Shift));
          ServoNo6.write(90+Leftoffset+AmplitudeSR*sin(Speed*Rads+3*Wave
lengths*Shift));

```



```

        ServoNo10.write(90+Offset+AmplitudeSW*sin(Speed*Rads+10*Wavelengths*Shift));
        delay(10);
        ServoNo11.write(90+Offset+AmplitudeSW*sin(Speed*Rads+11*Wavelengths*Shift+Pi/2));
        ServoNo12.write(90+Offset+AmplitudeSW*sin(Speed*Rads+12*Wavelengths*Shift));
        delay(10);
    }
}
if(results.value == 16720605)//if key Prev pressed
(results.value == key DEC code)
{
    for(int i=0; i<360; i++){
        Rads=i*Pi/180.0;    //convert from degrees to radians
        // Sidewinding left
        ServoNo1.write(90+Offset+AmplitudeSW*sin(Speed*Rads+1*Wavelengths*Shift));
        ServoNo2.write(90+Offset+AmplitudeSW*sin(Speed*Rads+2*Wavelengths*Shift+Pi/2));
        delay(10);
        ServoNo3.write(90+Offset+AmplitudeSW*sin(Speed*Rads+3*Wavelengths*Shift));
        ServoNo4.write(90+Offset+AmplitudeSW*sin(Speed*Rads+4*Wavelengths*Shift+Pi/2));
        delay(10);
        ServoNo5.write(90+Offset+AmplitudeSW*sin(Speed*Rads+5*Wavelengths*Shift));
        ServoNo6.write(90+Offset+AmplitudeSW*sin(Speed*Rads+6*Wavelengths*Shift+Pi/2));
        delay(10);
        ServoNo7.write(90+Offset+AmplitudeSW*sin(Speed*Rads+7*Wavelengths*Shift));
        ServoNo8.write(90+Offset+AmplitudeSW*sin(Speed*Rads+8*Wavelengths*Shift+Pi/2));
        delay(10);
        ServoNo9.write(90+Offset+AmplitudeSW*sin(Speed*Rads+9*Wavelengths*Shift));
        ServoNo10.write(90+Offset+AmplitudeSW*sin(Speed*Rads+10*Wavelengths*Shift+Pi/2));
        delay(10);
        ServoNo11.write(90+Offset+AmplitudeSW*sin(Speed*Rads+11*Wavelengths*Shift));
        ServoNo12.write(90+Offset+AmplitudeSW*sin(Speed*Rads+12*Wavelengths*Shift+Pi/2));
        delay(10);
    }
}
    Straightline();
}
else if(results.value == 16716015)//if key 4 pressed
(results.value == key DEC code)
{
    // 1 or 2 or 3

```



```

while(results.value != 16724175 || results.value != 16718055
|| results.value != 16743045 ){

    if(results.value == 16712445)//if key Next pressed
(results.value == key DEC code)
    { // Sidewinding clockwise
        for(int i=0; i<360; i++){
            Rads=i*Pi/180.0; //convert from degrees to radians
            // Sidewind turn clockwise
            ServoNo1.write(90+Offset+AmplitudeSW*sin(Speed*Rads+1*Waveleng
ths*Shift+Pi/2));
            ServoNo2.write(90+Offset+AmplitudeSW*sin(Speed*Rads+2*Waveleng
ths*Shift));
            delay(10);
            ServoNo3.write(90+Offset+AmplitudeSW*sin(Speed*Rads+3*Waveleng
ths*Shift+Pi/2));
            ServoNo4.write(90+Offset+AmplitudeSW*sin(Speed*Rads+4*Waveleng
ths*Shift));
            delay(10);
            ServoNo5.write(90+Offset+AmplitudeSW*sin(Speed*Rads+5*Waveleng
ths*Shift+Pi/2));
            ServoNo6.write(90+Offset+AmplitudeSW*sin(Speed*Rads+6*Waveleng
ths*Shift));
            delay(10);
            ServoNo7.write(90+Offset+AmplitudeSW*sin(Speed*Rads+7*Waveleng
ths*Shift));
            ServoNo8.write(90+Offset+AmplitudeSW*sin(Speed*Rads+8*Waveleng
ths*Shift+Pi/2));
            delay(10);
            ServoNo9.write(90+Offset+AmplitudeSW*sin(Speed*Rads+9*Waveleng
ths*Shift));
            ServoNo10.write(90+Offset+AmplitudeSW*sin(Speed*Rads+10*Wavele
ngths*Shift+Pi/2));
            delay(10);
            ServoNo11.write(90+Offset+AmplitudeSW*sin(Speed*Rads+11*Wavele
ngths*Shift));
            ServoNo12.write(90+Offset+AmplitudeSW*sin(Speed*Rads+12*Wavele
ngths*Shift+Pi/2));
            delay(10);

        }

    }
    if(results.value == 16720605)//if key Prev pressed
(results.value == key DEC code)
    {
        for(int i=0; i<360; i++){
            Rads=i*Pi/180.0; //convert from degrees to radians
            // Sidewinding turn anticlockwise
            ServoNo1.write(90+Offset+AmplitudeSW*sin(Speed*Rads+1*Waveleng
ths*Shift+Pi/2));
            ServoNo2.write(90+Offset+AmplitudeSW*sin(Speed*Rads+2*Waveleng
ths*Shift));
            delay(10);
            ServoNo3.write(90+Offset+AmplitudeSW*sin(Speed*Rads+3*Waveleng
ths*Shift+Pi/2));

```



```

    ServoNo12.write(90);
    delay(15);

    delay(1000);
}

void Serpentine_motion(){

    for(int i=0; i<360; i++){
        Rads=i*Pi/180.0;        //convert from degrees to radians

        ServoNo2.write(90+Offset+AmplitudeSR*sin(Speed*Rads+1*Wavelengths*Shift));
        ServoNo4.write(90+Offset+AmplitudeSR*sin(Speed*Rads+2*Wavelengths*Shift));
        ServoNo6.write(90+Offset+AmplitudeSR*sin(Speed*Rads+3*Wavelengths*Shift));
        ServoNo8.write(90+Offset+AmplitudeSR*sin(Speed*Rads+4*Wavelengths*Shift));
        ServoNo10.write(90+Offset+AmplitudeSR*sin(Speed*Rads+5*Wavelengths*Shift));
        ServoNo12.write(90+Offset+AmplitudeSR*sin(Speed*Rads+6*Wavelengths*Shift));
        delay(10);
    }
}

void Rectilinear_motion(){
    for(int Postion = 0; Postion < Flexangle; Postion += 1){
        ServoNo1.write(90-Postion);
        ServoNo3.write(90+2*Postion);
        ServoNo5.write(90-Postion);
        delay(15);
    }

    for(int Postion = 0; Postion < Flexangle; Postion += 1){
        ServoNo1.write(90-Flexangle+Postion);
        ServoNo3.write(90+2*Flexangle-3*Postion);
        ServoNo5.write(90-Flexangle+3*Postion);
        ServoNo7.write(90-Postion);
        delay(15);
    }

    for(int Postion = 0; Postion < Flexangle; Postion += 1){
        ServoNo3.write(90-Flexangle+Postion);
        ServoNo5.write(90+2*Flexangle-3*Postion);
        ServoNo7.write(90-Flexangle+3*Postion);
        ServoNo9.write(90-Postion);
        delay(15);
    }

    for(int Postion = 0; Postion < Flexangle; Postion += 1){
        ServoNo5.write(90-Flexangle+Postion);
        ServoNo7.write(90+2*Flexangle-3*Postion);
        ServoNo9.write(90-Flexangle+3*Postion);
    }
}

```

```
ServoNo11.write(90-Postion);  
delay(15);  
}  
  
for(int Postion = 0; Postion < Flexangle; Postion += 1){  
  ServoNo7.write(90-Flexangle+Postion);  
  ServoNo9.write(90+2*Flexangle-2*Postion);  
  ServoNo11.write(90-Flexangle+Postion);  
  delay(15);  
}  
}
```